



TURBOTWISTER®

ASSEMBLY AND INSTALLATION INSTRUCTIONS



WARNING

S.R. SMITH TURBOTWISTER SLIDES ARE MANUFACTURED FOR INSTALLATION AND USE ON RESIDENTIAL INGROUND SWIMMING POOLS ONLY. THE TURBOTWISTER IS NEVER TO BE INSTALLED AND USED ON ABOVEGROUND POOLS, ONGROUND POOLS, HOUSEBOATS, BOAT DOCKS, FLOATING DOCKS OR PLATFORMS OR OTHER BODIES OF WATER SUCH AS LAKES, PONDS, RIVERS, ETC.

SRS AUSTRALIA, PTY LTD
12 Enterprise St
Richlands QLD 4077
Australia
Phone 07 3812 2283
www.srsmith.com/en-au

S.R. SMITH, LLC
CORPORATE HEADQUARTERS
P.O. Box 400 • 1017 S.W. Berg Parkway
Canby, Oregon 97013
USA
Tel: 1 (800) 824-4387
www.srsmith.com

TABLE OF CONTENTS

INTRODUCTION..... 3

INSTALLED TURBOTWISTER STRUCTURAL & INSTALLATION CHECKLIST 4

MAINTENANCE INSTRUCTIONS 4

ASSEMBLED TURBOTWISTER LAYOUT 5

ASSEMBLY INSTRUCTIONS..... 6

 Tools Required 6

 Gasket Installation..... 6

MAIN SECTION PARTS LIST..... 7

MAIN SECTION ASSEMBLY 8

CONCRETE WEDGE ANCHOR MOUNTING INSTRUCTIONS 16

WATER SYSTEM PARTS LIST 18

WATER SYSTEM ASSEMBLY 19

MANUFACTURER’S PLACEMENT INSTRUCTIONS 22

SLIDE ASSEMBLY AND INSTALLATION VIDEOS AVAILABLE AT
www.youtube.com/srsmithllc

REGISTER YOUR S.R. SMITH PRODUCT AT
www.srsmith.com/en/customer-service/product-registration



Visit srsmith.com for information on the complete line of S.R.Smith pool products.

INTRODUCTION



DANGER – FAILURE TO FOLLOW THESE WARNINGS, INSTRUCTIONS, AND THE OWNER’S MANUAL MAY RESULT IN SERIOUS INJURY OR DEATH.

TURBOTWISTER IS DESIGNED AND MANUFACTURED FOR INSTALLATION AND USE ON INGROUND SWIMMING POOLS ONLY. DO NOT INSTALL THIS SLIDE ON ABOVE GROUND POOLS, HOUSEBOATS, BOAT DOCKS, FLOATING DOCKS OR PLATFORMS, OR OTHER BODIES OF WATER SUCH AS LAKES, PONDS, RIVERS, ETC. PROPER ASSEMBLY, INSTALLATION, USE, AND SUPERVISION ARE ESSENTIAL FOR PROPER OPERATION AND TO REDUCE THE RISK OF SERIOUS INJURY OR DEATH.

ALL NATIONAL AND LOCAL BUILDING CODES MUST BE FOLLOWED. THIS INCLUDES ANY APPLICABLE REQUIREMENTS FOR SIZE OF CONCRETE FOOTING, OVERALL HEIGHT OF SLIDE, AND BODING OR ELECTRICAL CODES.

CHECK INSIDE ALL BOXES AND PACKAGING MATERIALS FOR PARTS. BEFORE BEGINNING ASSEMBLY, READ ALL INSTRUCTIONS AND IDENTIFY PARTS USING THE FIGURES AND PARTS LISTED IN THIS DOCUMENT. IT IS CRITICAL THAT ALL PARTS BE CAREFULLY INSPECTED BY THE INSTALLER PRIOR TO INSTALLATION TO ENSURE THAT NO DAMAGE OCCURRED IN TRANSIT AND THAT A DAMAGED PART IS NOT USED. PROPER INSTALLATION CANNOT BE OVERSTRESSED, IMPROPER INSTALLATION VOIDS S.R. SMITH’S WARRANTY AND MAY AFFECT THE SAFETY OF THE USER.

INSTALLER MUST GIVE TO SLIDE OWNER: TURBOTWISTER INSTALLATION AND OWNER’S MANUAL, THE WARRANTY CARD, AND ANSWER ALL QUESTIONS REGARDING SAFE AND PROPER USE AND SLIDE MAINTENANCE.

FOR COMPLETE SLIDE SAFETY INFORMATION REFER TO THE OWNER’S MANUAL.

INSTALLED TURBOTWISTER STRUCTURAL & INSTALLATION CHECKLIST

Installer to review with slide owner upon completion of slide installation.

1. Inspect the runway for visible cracks or tears.
2. Inspect the ladder for sharp edges, protrusions, cracks, or tears.
3. Inspect all fasteners to make sure they are fully tightened.
4. Inspect the ladder for rigidity and attachment.
5. Measure the following dimensions and compare with the manufacturer's placement instructions on pages 22-24.
 - Pool water depth at the base of the slide should be at least 3'-0" (0.914 M) deep, and at 4'-6" (1.372 M) out from slide exit, should be at least 4'-6" (1.372 M) deep.
 - The height of the slide runway exit above the water should be 20" (0.508 M) maximum.
 - The distance between the slide centerline and the edge of other pool equipment should be at least 3'-6" (1.067 M).
6. Observe the position of the exit of the slide as shown in Figure W, Figure X, and Figure Z, on pages 22 and 24.

MAINTENANCE INSTRUCTIONS

1. When hosing down the deck, hose your TurboTwister to wash away any dust, dirt or other debris that may have accumulated.
2. Be sure that all connections are secure. Tighten hardware if necessary.
3. All polyethylene parts require little maintenance. Hose and wipe to clean. While cleaning slide, check and see that all nuts and bolts are tight and secure.
4. Inspect the runway for visible cracks or tears, sharp edges and protrusions.
5. Inspect all attachment points for loose or corroded fasteners.
6. Inspect all ladder tread or step-attachment points for evidence of shear, bending yield, or fatigue in the ladder steps, rails, or attachment means. Yield is evidenced by crystallization or fine cracking of the ladder tread and/or surface.
7. Inspect the ladder handrails for rigidity and attachment.

ASSEMBLED TURBOTWISTER LAYOUT

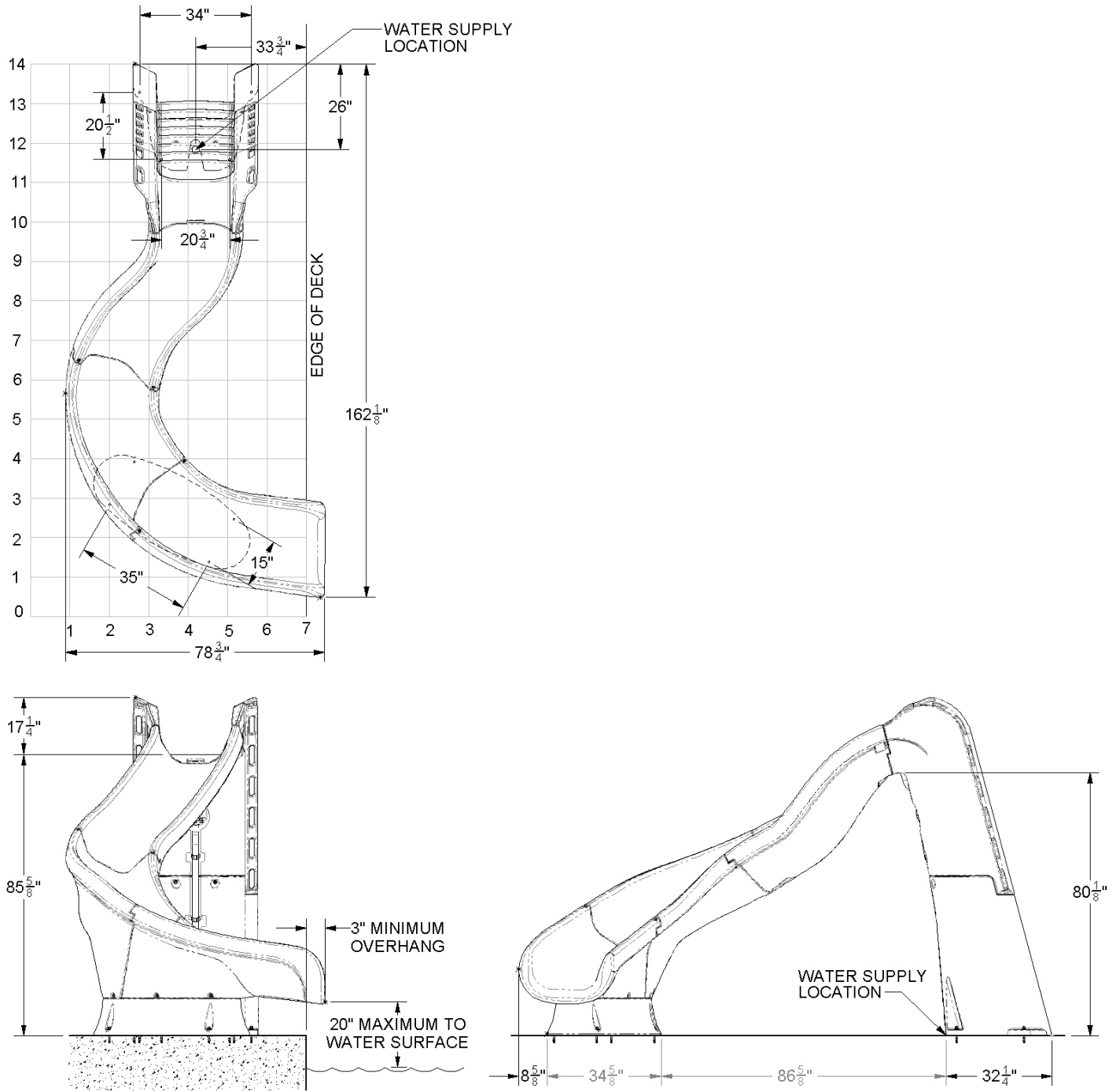

The left curve TurboTwister is shown for illustration.
The right curve TurboTwister is a mirror image of the left.

Figure A

ASSEMBLY INSTRUCTIONS

Tools Required

1. Ratchet handle
2. 9/16" deep socket
3. 9/16" wrench
4. 3/4" socket or wrench
5. 7/32" Allen wrench
6. Phillips head screwdriver
7. 1/2"Ø (12.7 mm) concrete drill bit
8. 1/4"Ø (6.3 mm) drill bit
9. Power drill
10. PVC pipe primer & glue
11. Anti-seize
12. Saw to cut PVC pipe
13. Knife
14. Level
15. Pistol-grip clamp (optional)

NOTE: Use pistol-grip clamps as necessary to align the molded parts.

Gasket Installation

- Most of the gasket material has been installed at the factory, however additional gasket has been provided in case any gasket has fallen off during shipping. If gasket installation is required, follow the instructions below in Figure B. The gasket on the face of the ladder is not installed in the factory, but detailed instructions are provided on page 12, Figure K.
- Apply gasket in the required locations as shown in Figure B.
- Place gasket along the section to determine the length needed.
- Cut gasket to appropriate length.
- Remove backing and adhere gasket to slide.
- All gaskets below are applied as shown in Figure B in the Joint / Gasket Cross-Section Detail.
- See page 12, Figure K, for further details on installing the ladder gasket, PN 8-560.

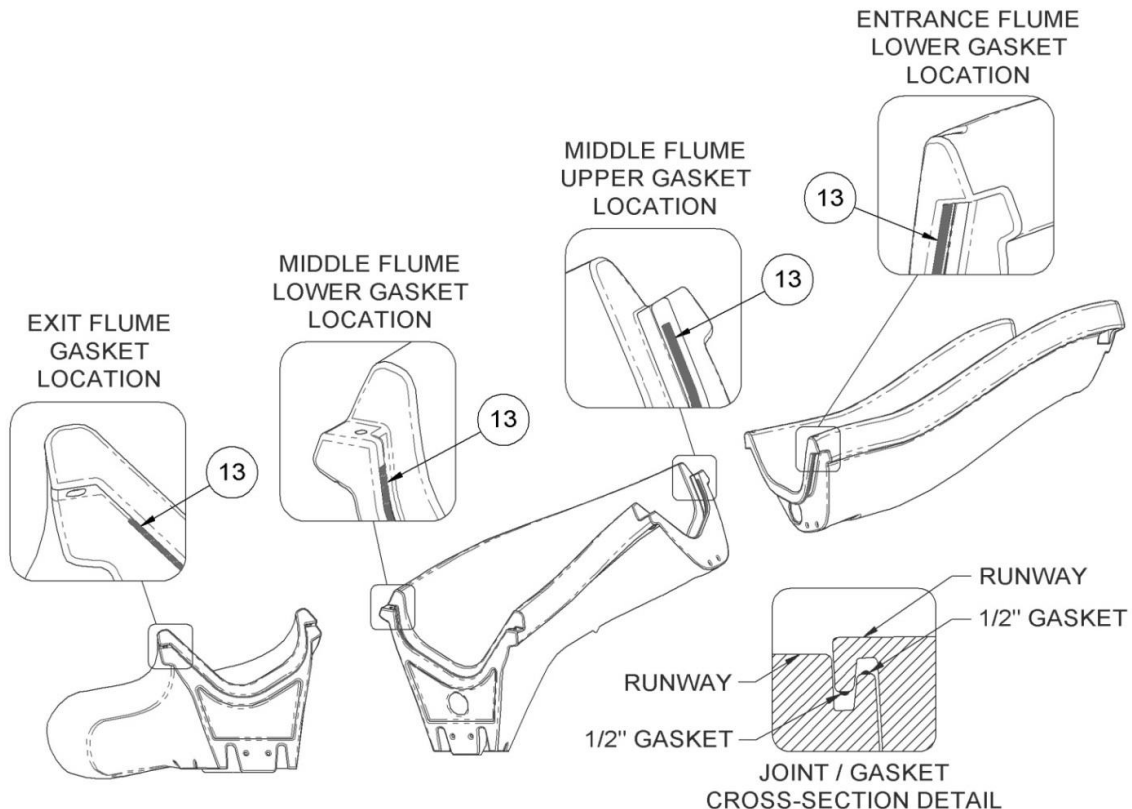

MAIN SECTION PARTS LIST

Figure B

ITEM NO.	PART NO.	DESCRIPTION	QTY.	KIT A
KIT A	69-209-168	TUROBOTWISTER HARDWARE CARTON	1 ea.	
1	5-139	3/8" HEX NUT	16 ea.	•
2	5-151	3/8" LOCK WASHER	16 ea.	•
3	05-14-115	1/2" LOCK WASHER	8 ea.	•
4	5-145	3/8" FLAT WASHER	37 ea.	•
5	5-235	3/8" x 2-1/4" CARRIAGE BOLT	2 ea.	•
6	5-236	3/8" x 2-1/4" BUTTON HEAD CAP SCREW	2 ea.	•
7	5-249	3/8" x 3-1/4" BUTTON HEAD CAP SCREW	4 ea.	•
8	5-239	3/8" x 2-1/2" STUD	4 ea.	•
9	5-240	3/8" x 3-1/2" LAG SCREW	9 ea.	•
10	5-237	3/8" x 5" BUTTON HEAD CAP SCREW	4 ea.	•
11	5-238	3/8" x 6" HEX HEAD CAP SCREW	4 ea.	•
12	5-241	1/2" x 5" CONCRETE WEDGE ANCHOR WITH HARDWARE	8 ea.	•
13	8-532	1/2" HIGH x 1/2" WIDE x 32" LONG RUBBER GASKET (NOT SHOWN)	1 ea.	
14	8-560A	TOP RUNWAY GASKET KIT (NOT SHOWN) – INCLUDES 3/8" X 3' ROUND RIBBON GASKET AND INSTRUCTION.	1 ea.	

Visit srsmith.com for hardware kit and replacement part information.

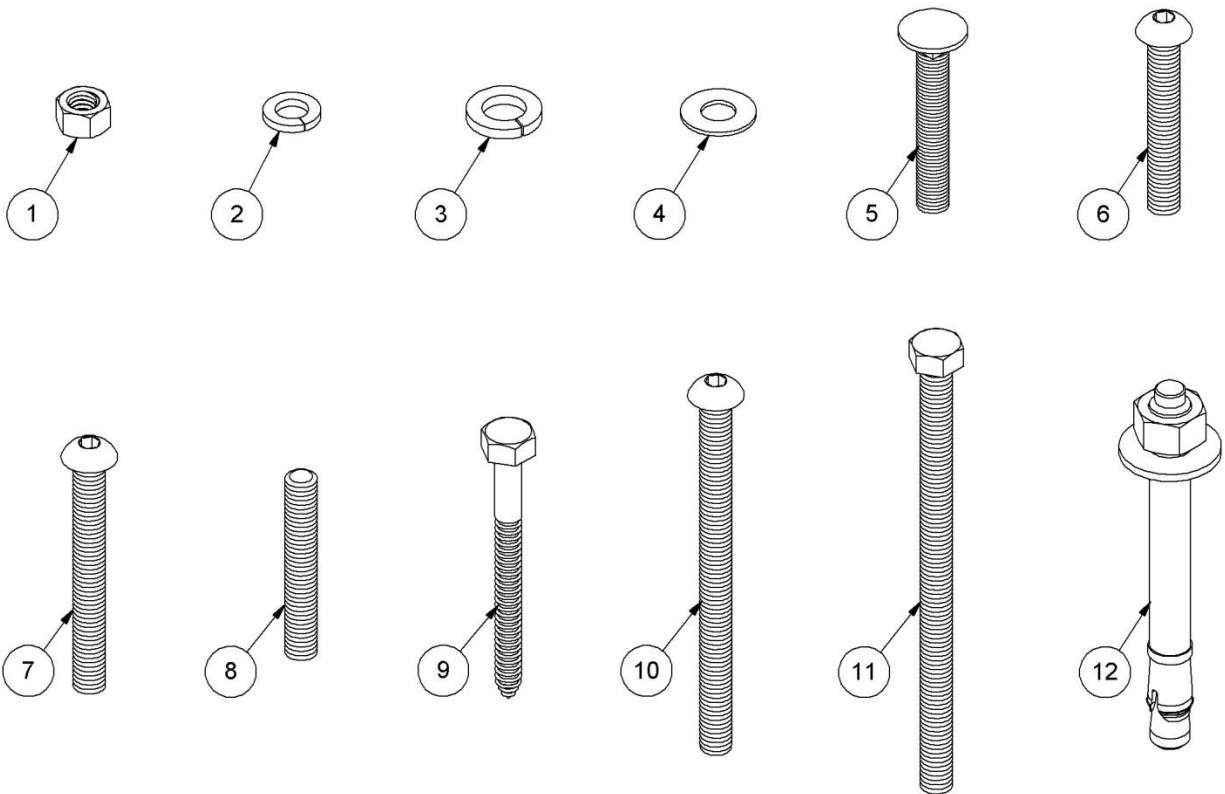

MAIN SECTION ASSEMBLY

1. Place the Pedestal on the ground and set the Exit Slide Section on top as shown in Figure C.

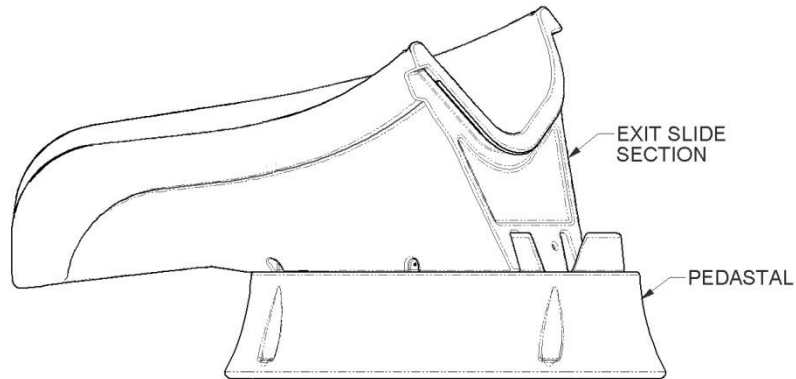

Figure C

2. Attach the Exit Slide Section to the Middle Slide Section as shown in Figure D. If necessary lift up on the end of the exit runway in order to keep the joint tight while fastening.

Note: Ensure gasket material at the joint is intact before assembling.

The required hardware is as follows: 3/8" x 5" Socket Head Cap Screw (10), 3/8" Flat Washer (4), 3/8" Flat Washer (4), 3/8" Lock Washer (2), 3/8" Hex Nut (1).

Note: When assembling the slide, apply a thin even coating of anti-seize to all stainless steel fasteners. Anti-Seize aids in assembly, prevents galling, and improves corrosion resistance. Anti-Seize can be purchased at most auto parts stores.

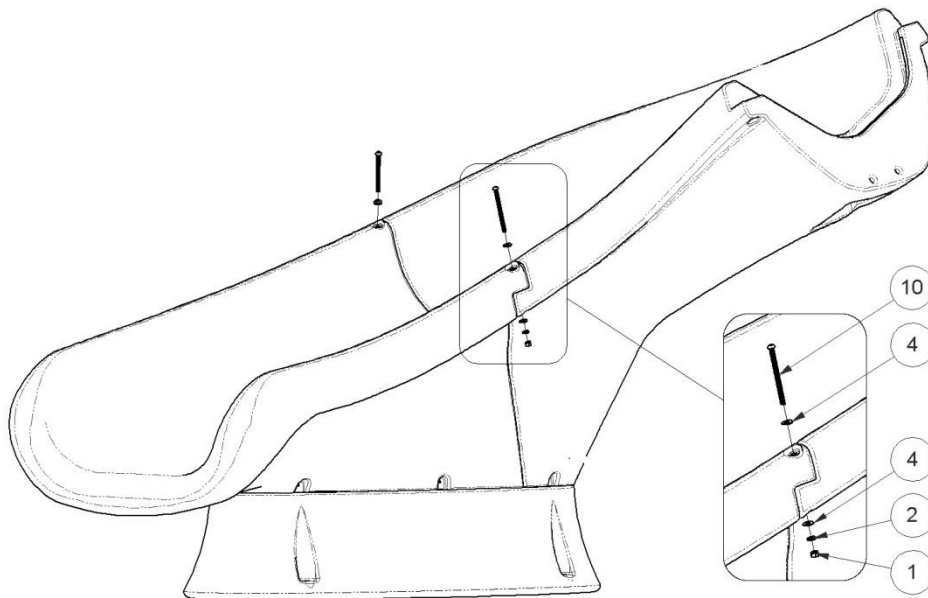

Figure D

3. Once the sidewall connections have been made, remove the assembled Exit and Middle Slide Sections from the Pedestal. Turn the assembly upside down and fasten the underside as shown in Figure E. The required hardware is as follows: 3/8" x 6" Hex Head Cap Screw (11), 3/8" Flat Washer (4), 3/8" Flat Washer (4), 3/8" Lock Washer (2), and 3/8" Hex Nut (1).

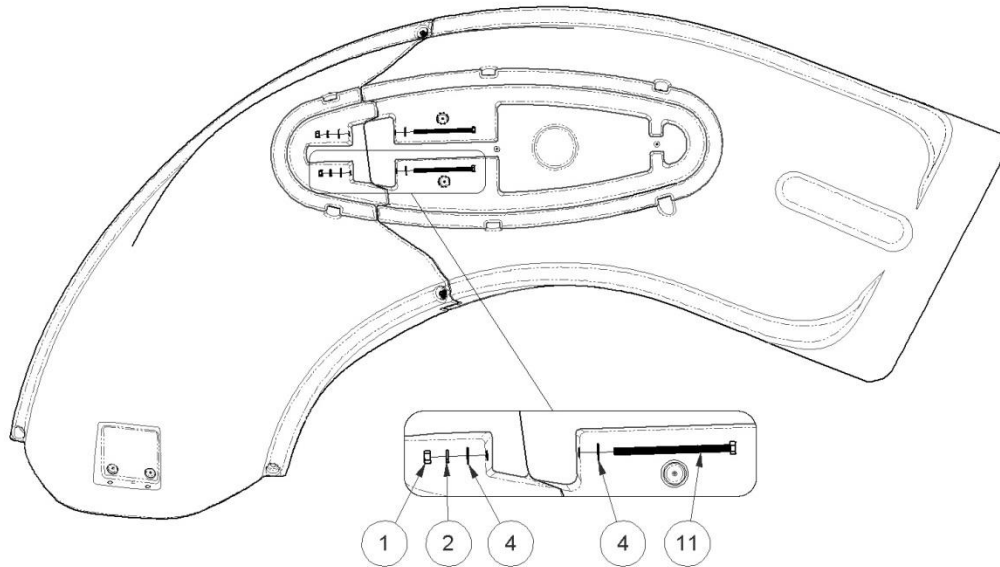

Figure E

4. Attach the Pedestal to the Middle Runway Section and Exit Slide Sections. Install the fasteners, as shown in Figure F. The required hardware is as follows: 3/8" x 3-1/2" Lag Screw (9), and 3/8" Flat Washer (4).

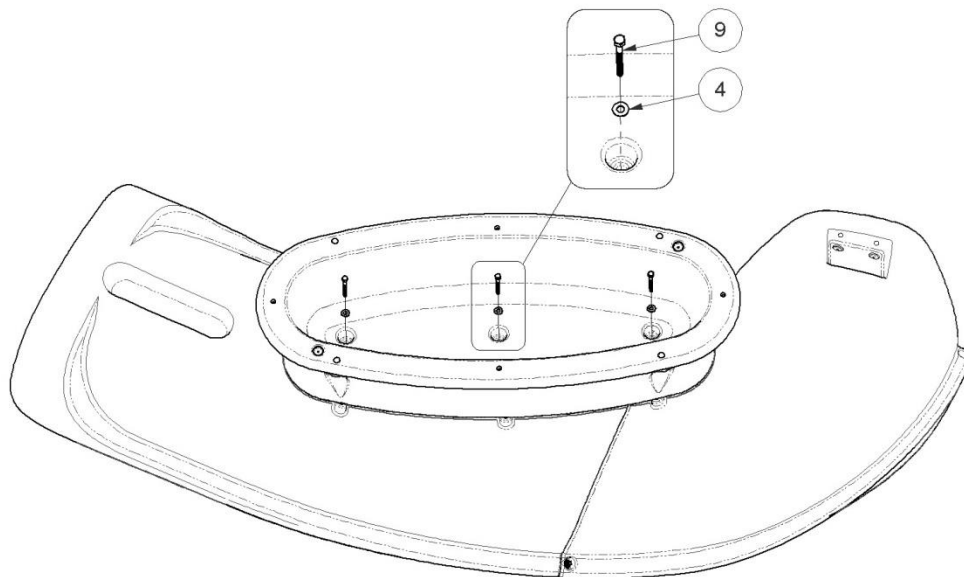

Figure F

5. Install four 3/8" x 2-1/2" Studs (8) into the threaded inserts located at the top of the ladder as shown in Figure G.

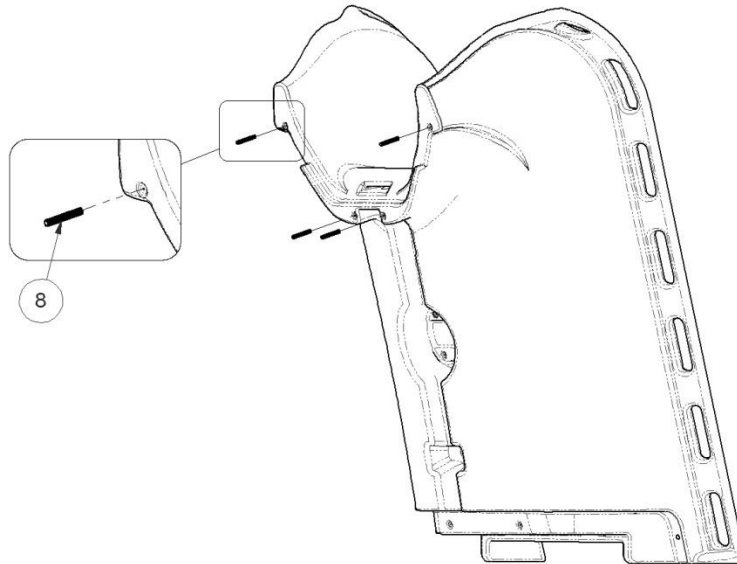

Figure G

6. Assemble the Top and Bottom Ladder Sections as shown in Figure H, Figure I, and Figure J. Do not fully tighten fasteners until all the hardware is in place. The hardware required for the connections on the back side of the ladder shown on the right in Figure H are as follows: 3/8" x 2-1/4" Button Head Cap Screw (6), and 3/8" Flat Washer (4). The hardware required for the connections on the ladder side rails shown on the left in Figure H are as follows: 3/8" x 3-1/4" Button Head Cap Screw (7), 3/8" Flat Washer (4), 3/8" Lock Washer (2), and 3/8" Hex Nut (1).

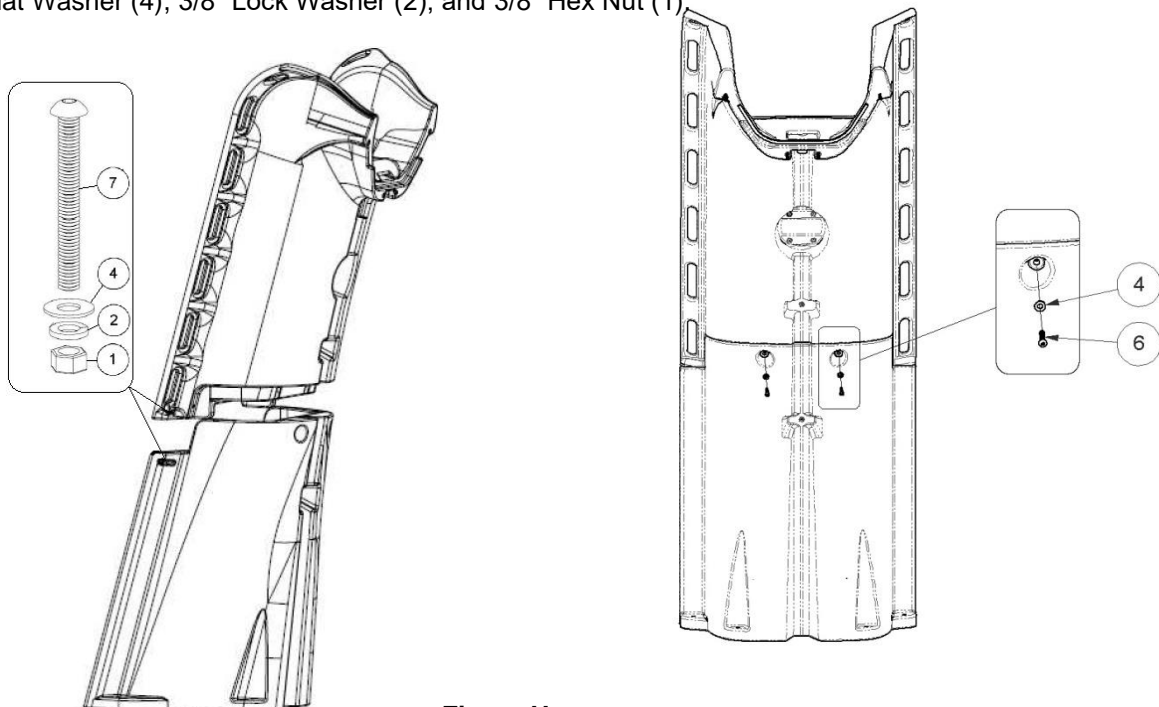

Figure H

7. The hardware required for the connections shown in Figure I are as follows: 3/8" x 3-1/4" Button Head Cap Screw (7) and 3/8" Flat Washer (4).

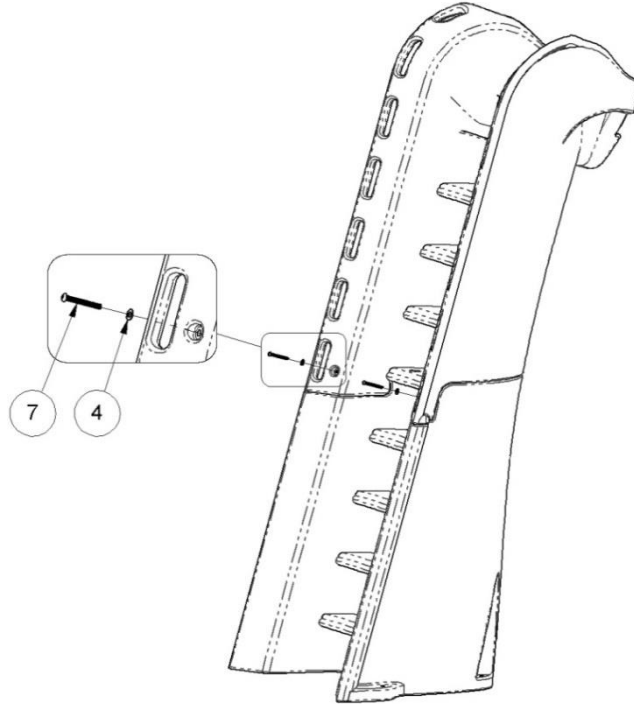

Figure I

8. The hardware required for the connections shown in Figure J are as follows: 3/8" x 2-1/4" Carriage Bolt (5), 3/8" Flat Washer (4), 3/8" Lock Washer (2), and 3/8" Hex Nut (1).

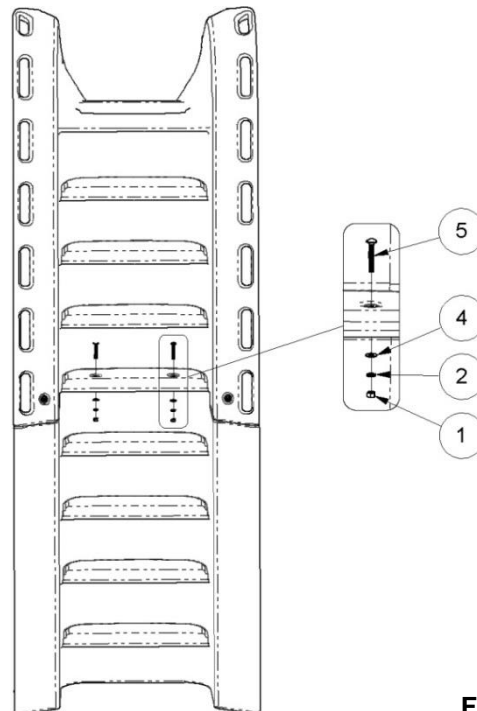

Figure J

9. For the butyl gasket, getting your hands wet will help prevent the material from sticking to them. **Be careful not to get the slide wet before installing the butyl gasket.**
- Be sure to keep the gasket and slide clean during the installation process.
 - While still wrapped, take the gasket material (Part Number 8-560) and hold so that that length of the gasket is centered on the center of the ladder joint.
 - Remove the protective tape and apply the gasket, working from center outwards as shown in Figure K. Be sure that the bottom edge of the gasket material is held against the shelf on the ladder part during installation; see reference images on the next page.
 - Do not make too tight of a bend radius with the gasket when transitioning the gasket up the vertical edges of the joint. The transition radius should be as large as possible.
 - The gasket should be centered on the available space in the vertical area of the joint; see reference images on the next page.
 - Once the gasket is in place, firmly press down on the gasket in all locations to ensure that the gasket has completely adhered to the ladder joint surface. Get your hands wet to prevent the butyl from sticking to your hands.
 - The final step is to install the top runway section onto the ladder section. **It is strongly recommended that two people are used for this step to ensure that the top runway section is aligned properly with the ladder section. It will be difficult to separate the parts once the gasket comes into contact with the top runway section, so it is important that the two parts are aligned correctly the first time.**

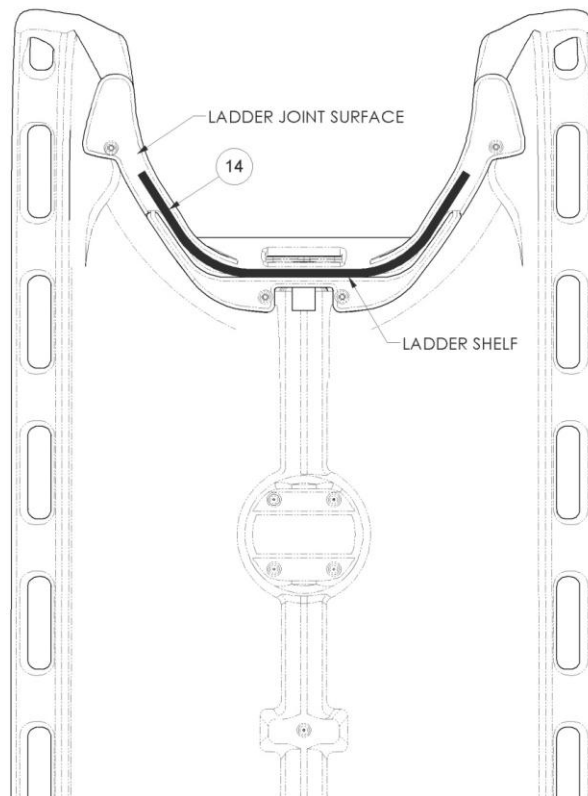

Figure K

Lay the Ladder assembly flat on the deck surface as shown in Figure L. Align the Upper Slide Runway's mounting holes with the four Studs in the Top Slide Section. The required hardware for these connections is as follows: 3/8" Flat Washer (4), 3/8" Lock Washer (2), and 3/8" Hex Nut (1).

Notes:

- Use caution to protect the ladder from being scratched during this step.
- It is strongly recommended that a second person assist to help ensure that the Top Runway Section is properly aligned with the Ladder Section. It is difficult to separate the parts once the gasket adhesive comes into contact with the Top Runway Section, so it is important that the two parts be aligned correctly the first time.

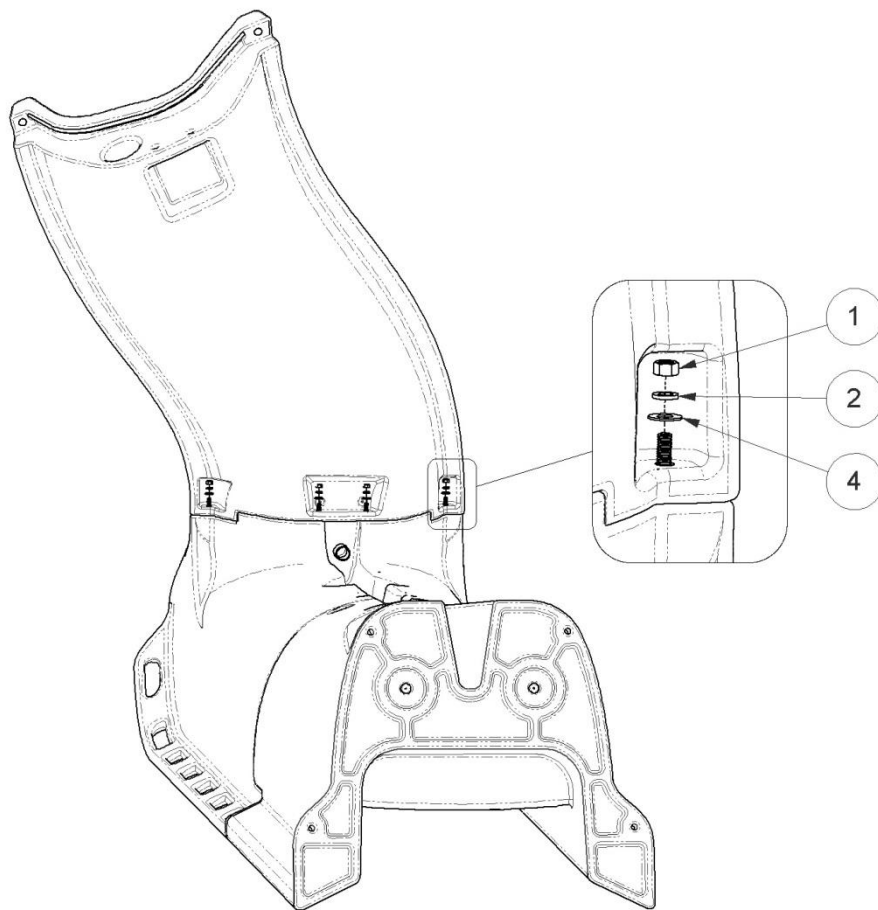

Figure L

Note: Ensure gasket material at the Runway joint is intact before assembling.

10. Stand the Ladder upright and assemble the Lower Slide Runway as shown in Figure M. Loosely install the fasteners for both of the Runway sidewall connections. The required hardware is as follows: 3/8" x 5" Socket Head Cap Screw (10), 3/8" Flat Washer (4), 3/8" Flat Washer (4), 3/8" Lock Washer (2), 3/8" Hex Nut (1).

11. Install the fasteners on the underside of the runway. The required hardware is as follows: 3/8" x 6" Hex Head Cap Screw (11), 3/8" Flat Washer (4), 3/8" Flat Washer (4), 3/8" Lock Washer (2), 3/8" Hex Nut (1). After all of the fasteners are in place, tighten them.

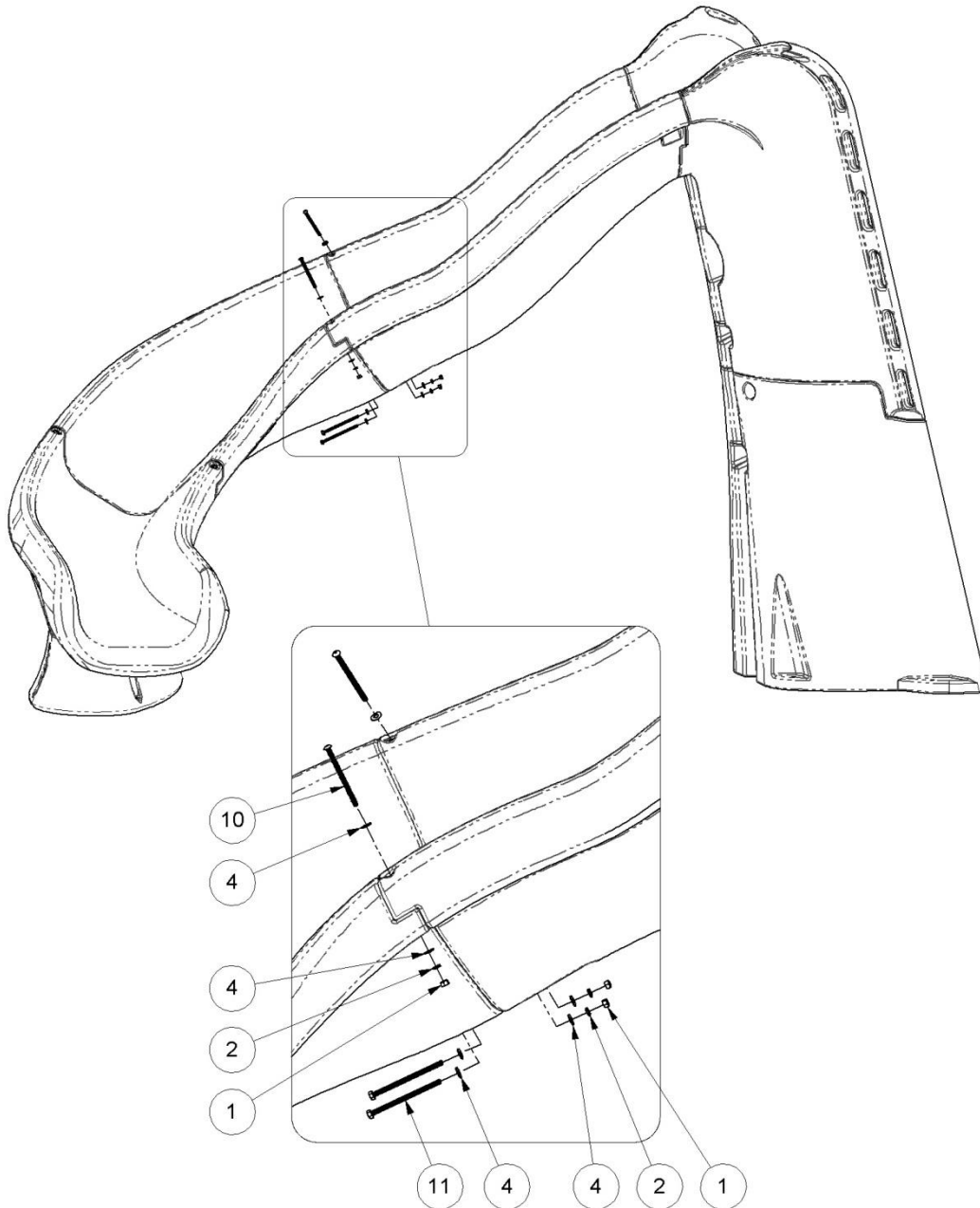

Figure M

12. Drill a 1/4"Ø pilot hole through the center of the 6 circular indentations around the perimeter of the Pedestal / Runway connection. Then install a 3/8" x 3-1/2" Lag Screw (9) and 3/8" Flat Washer (4) as shown in Figure N.

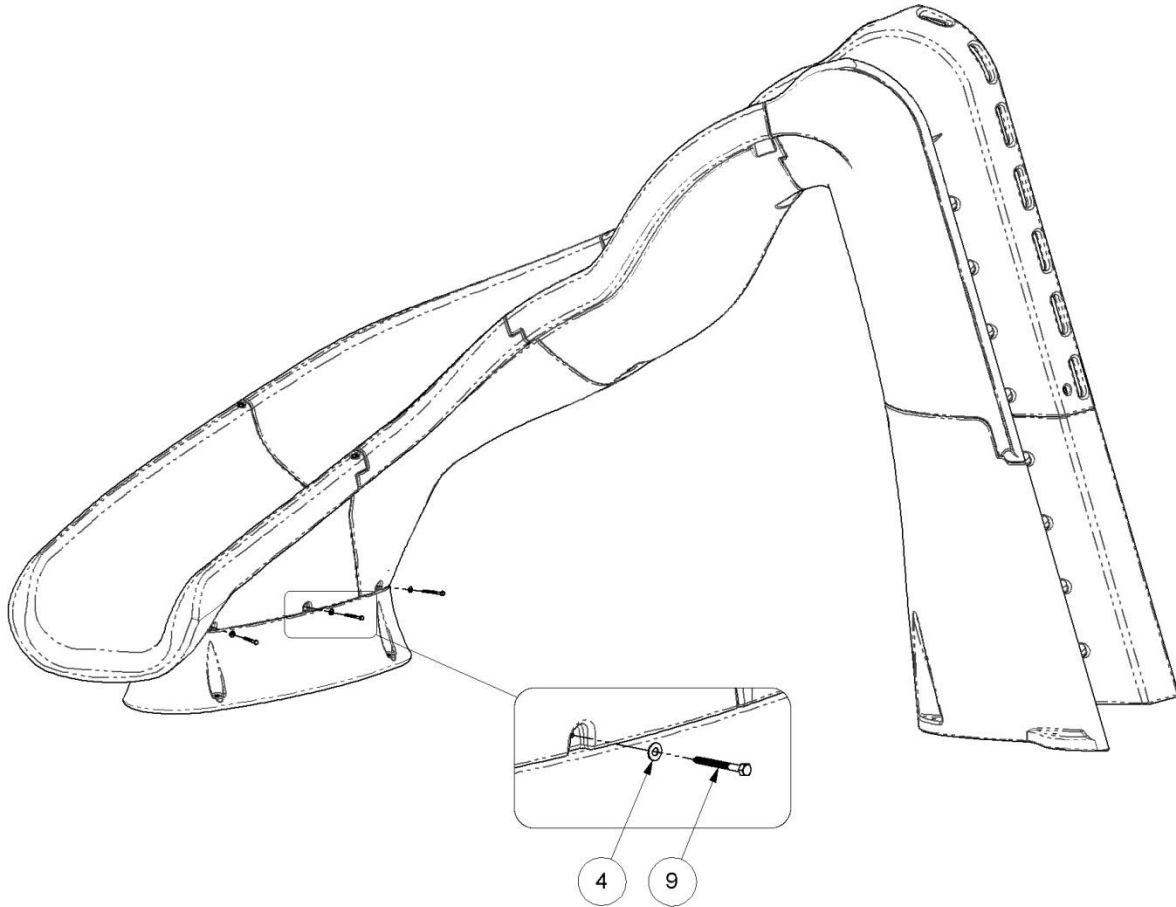

Figure N

CONCRETE WEDGE ANCHOR MOUNTING INSTRUCTIONS

1. Position the assembled slide on the deck relative to the pool wall. Ensure that the exit flume clears any coping. Slide may be angled slightly providing all dimensions are maintained as noted in the **“Manufacturer’s Placement Instructions”** noted on pages 22 and 24.
2. The TurboTwister slide must be anchored into a concrete pad that is a minimum of 4” thick. If installing the slide on a paver deck, refer to S.R. Smith instruction 06-520 **“Installation Instructions for Paver Decks”**.
3. With the slide in its proper location, center punch or otherwise mark through the (8) mounting holes at the bottom of the Ladder and Pedestal so that a visible mark is apparent on the concrete.
4. In order to protect the slide from being damaged by the drill bit, move the slide aside before drilling the holes into the concrete deck.
5. Using a power drill and a 1/2”Ø concrete drill bit, drill the holes to a depth of 4”. Use tape or a marking on the drill bit to ensure that the hole for the anchor is drilled to the required depth. Keep the drill straight and perpendicular to the deck surface while drilling in order to maintain proper holding strength of the concrete wedge anchors (12).
6. Clear the newly drilled holes of all debris.
7. Move the slide back over the holes. Assemble the Wedge Anchor Stud (12) with the Wedge Anchor Hex Nut (12) and the Wedge Anchor Flat Washer (12) so that the top of the Wedge Anchor Hex Nut (12) is flush with the top of the Wedge Anchor Stud (12), and insert the assembled Wedge Anchors (12) into the slide’s mounting holes as shown in Figure O.

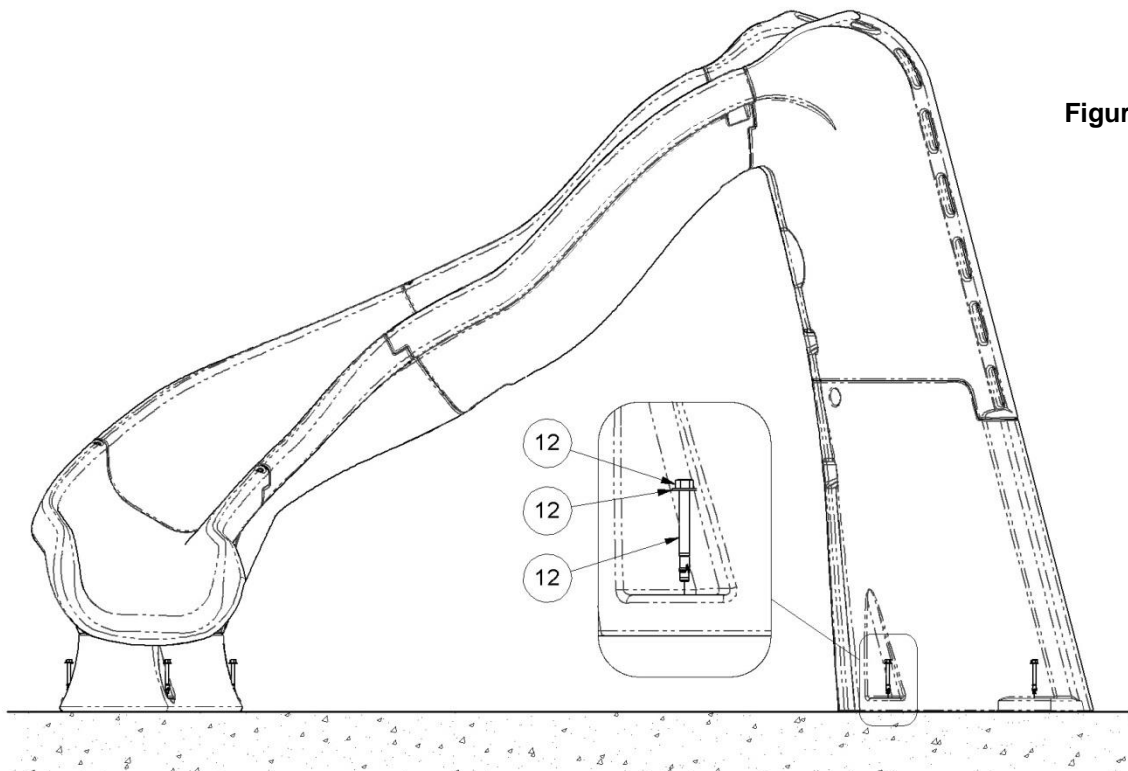

Figure O

8. Drive the assembled Wedge Anchors (12) through the slide mounting holes until the Wedge Anchor Flat Washers are flush with the slide's surface material, as shown in Figure P.

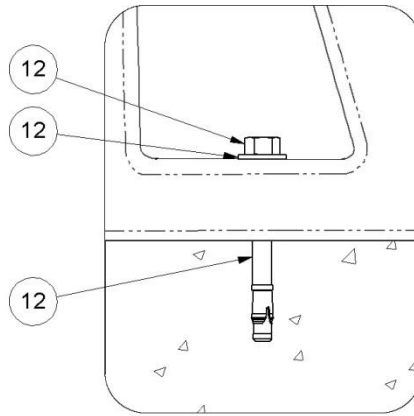

Figure P

9. Ensure the Slide Ladder is plumb by placing a level on a Ladder tread. If necessary, shims can be provided by S.R. Smith to place beneath the base of the Ladder to ensure it is plumb due to varying deck slopes. Call S.R. Smith at 800-824-4387 if shims are needed.
10. Expand the Wedge Anchor Stud (12) by tightening the Wedge Anchor Hex Nut (12) 3 to 5 turns. Once the Wedge Anchor (12) is set, remove Wedge Anchor Hex Nut (12) and install a 1/2" Lock Washer (3) between the Wedge Anchor Flat Washer (12) and Hex Nut (12).
11. Then retighten the Hex Nut (12) to a torque of 25 ft.-lbs. (33.9 N-m). See Figure Q for final assembly.

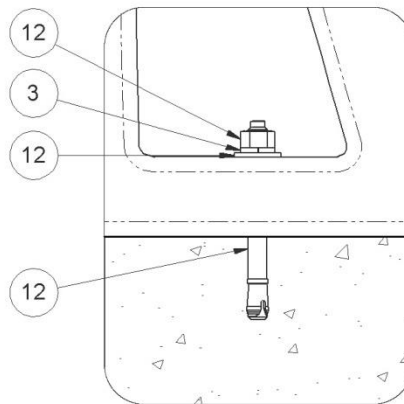
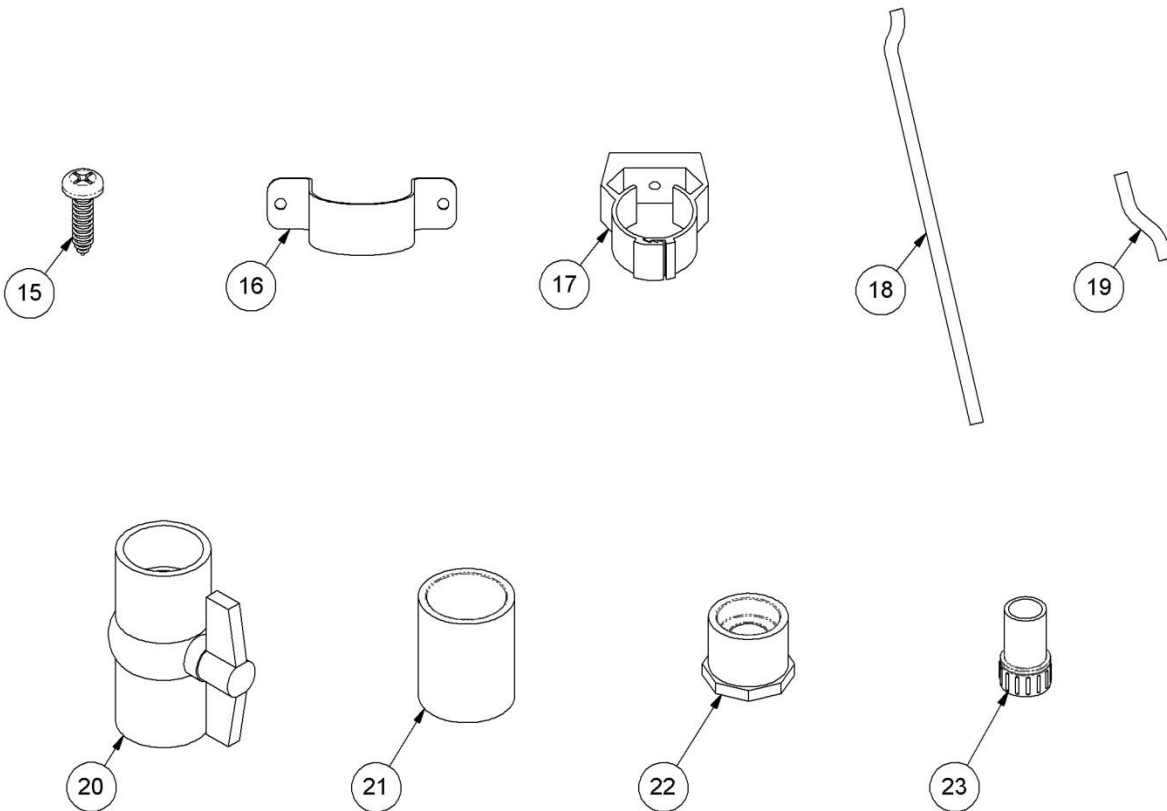

Figure Q

WATER SYSTEM PARTS LIST

ITEM NO.	PART NO.	DESCRIPTION	QTY.	KIT A
KIT A	69-209-168	TUROBOTWISTER HARDWARE CARTON	1 ea.	
15	5-242	#14 x 1" PAN HEAD TAPPING SCREW	6 ea.	•
16	05-787	2"Ø PVC PIPE STRAP	2 ea.	•
17	05-788	1-1/2"Ø PIPE CLAMP	2 ea.	•
18	05-789-2	1-1/2"Ø PVC FLEX HOSE, 6'-0" LONG	1 ea.	
19	05-789-1	1-1/2"Ø PVC FLEX HOSE, 15" LONG	1 ea.	
20	05-777	1-1/2"Ø BALL VALVE	1 ea.	•
21	05-781	1-1/2"Ø COUPLING	1 ea.	•
22	05-780	1-1/2"Ø x 3/4"Ø REDUCER	1 ea.	•
23	05-779	GARDEN HOSE ADAPTER	1 ea.	•

Visit srsmith.com for hardware kit and replacement part information.



WATER SYSTEM ASSEMBLY

Note: It's a good idea to dry fit all of the plumbing parts before gluing them together so you can make adjustments accordingly.

1. Temporarily assemble the two lengths of 1-1/2"Ø Flex Hose (18) and (19) to the 1-1/2"Ø Ball Valve (20). Then insert the 1-1/2"Ø Coupling (21) to the opposite end of the longer 1-1/2"Ø Flex Hose (18), as shown in Figure R.



Figure R

2. Make alignment marks on the parts with a pencil before disassembling. This will aid in reassembling the parts while gluing them together.
3. Use PVC primer and glue to reassemble the plumbing parts.
4. Fasten the two 1-1/2"Ø Pipe Clamps (17) to the slide using #14 x 1" Pan Head Tapping Screws (15), as shown in Figure S.

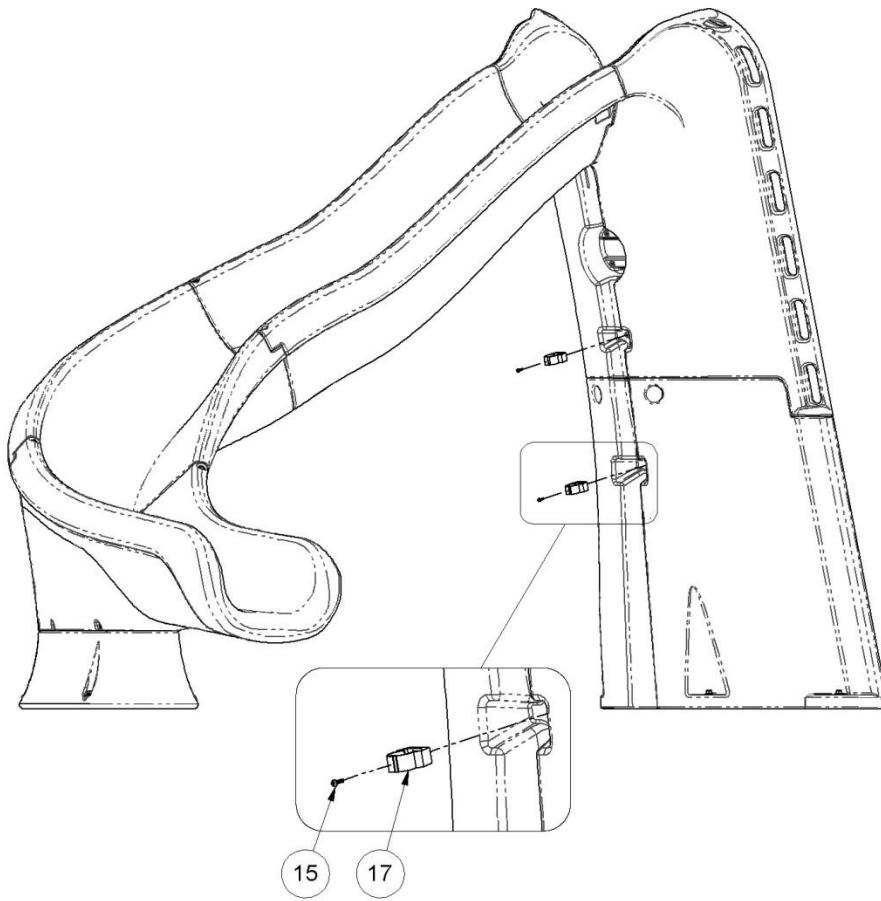

Figure S

5. Glue assembled water supply pipe onto the 1-1/2"Ø PVC fitting at the top of the slide, as shown in Figure T.

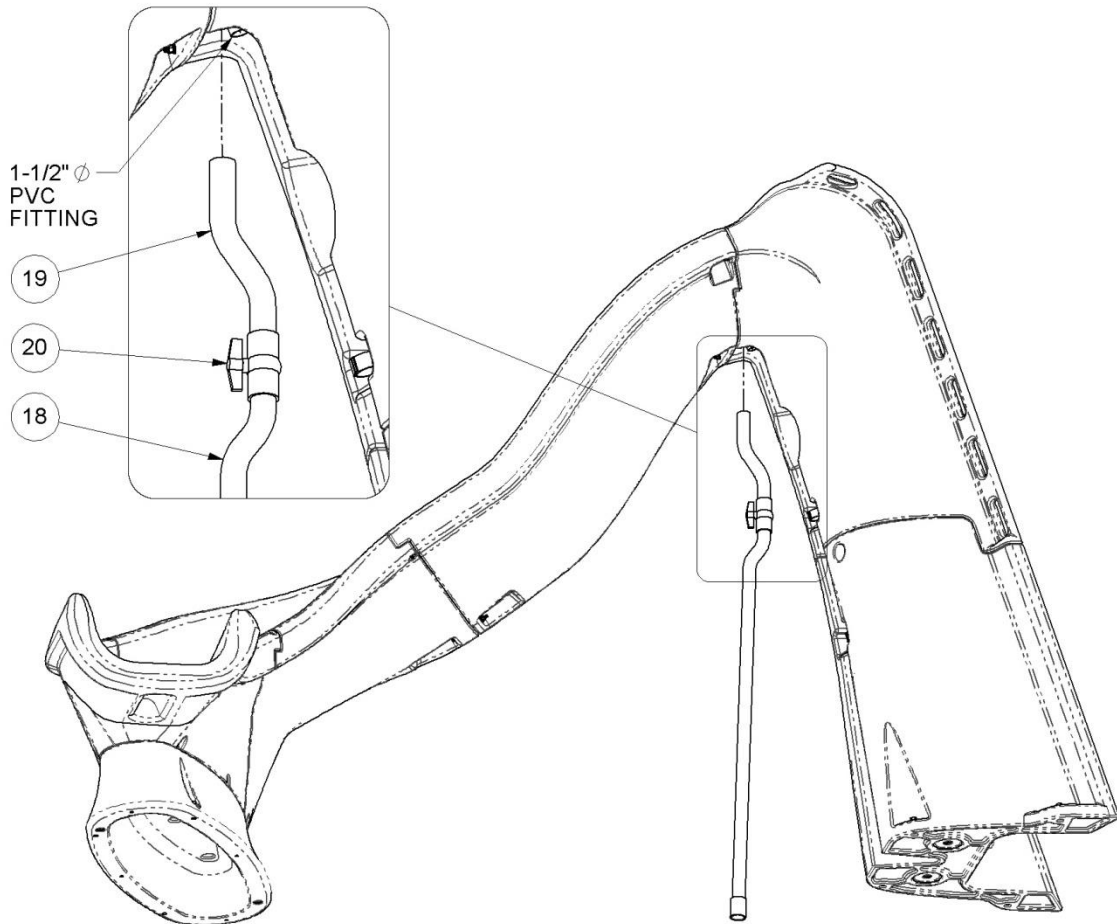

Figure T

6. Secure the 1-1/2"Ø Flex Hose (18) to the ladder with the two 1-1/2"Ø Pipe Clamps (17) that were installed previously in Step 4, on page 19.
7. Secure the 1-1/2"Ø Ball Valve (20) with two 2"Ø Pipe Straps (16). Install them with the #14 x 1" Pan Head Tapping Screws (15), as shown in Figure U.

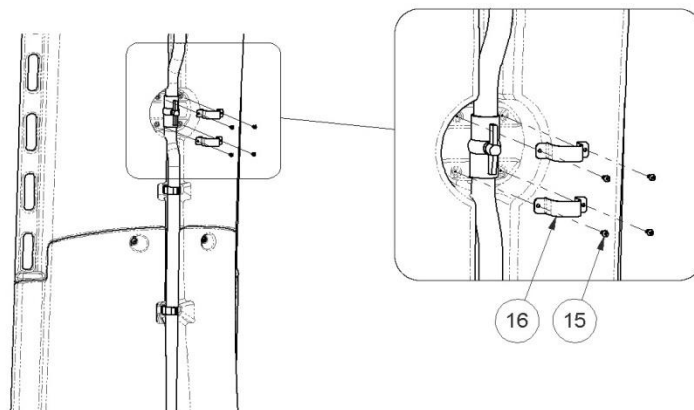

Figure U

8. The TurboTwister is designed to connect to a 1-1/2"Ø water supply line. Plumb the water supply "stub up" at the base of the slide's ladder, where the lower end of the 1-1/2"Ø Flex Hose (18) is located. The "stub up" should be installed prior to mounting the slide to the deck. The "stub up" should be dark grey PVC to match the slide's plumbing assembly. Extend the water supply "stub up" to a height of 18" above the deck. It can be cut to the desired length later, during the installation process.
9. Attach the "stub up" to the plumbing assembly installed in the slide as necessary.
10. If a garden hose is going to be used to supply water to the slide, glue the Garden Hose Adapter (23) and the 1-1/2"Ø x 3/4"Ø Reducer (22) together and then glue them into the bottom of the 1-1/2"Ø Coupler (21), as shown in Figure V.

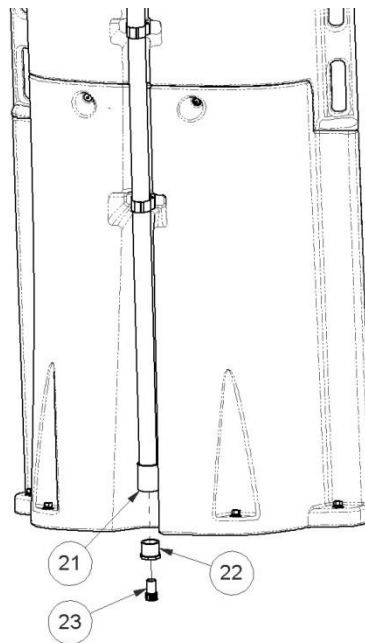

Figure V

11. The TurboTwister can handle up to 25 gallons of water per minute (95L/min). The water flow can be regulated with the 1-1/2"Ø Ball Valve (20).

MANUFACTURER'S PLACEMENT INSTRUCTIONS

PROPER ASSEMBLY, INSTALLATION, USE, AND SUPERVISION ARE ESSENTIAL FOR PROPER OPERATION AND TO REDUCE THE RISK OF SERIOUS INJURY.

1. The critical dimensions for placement of the TurboTwister are as shown in Figure W and Figure X.
 - A. The slide exit runway surface shall not exceed 20" above the water surface as shown in Figure W.
 - B. The slide shall be positioned so that all water flowing off the runway exit drops into the pool. The recommended overhang is 4".
 - C. The minimum depth of water below the exit lip of the slide shall be 3'-0" and increase to 4'-6" at Point A, which is a distance of 4'-6" from the exit lip of the slide as shown in Figure W.
 - D. A minimum depth of 4'-6" shall be maintained at a distance of 9'-0" along the extended centerline of the slide from Point A, as shown in Figure W.

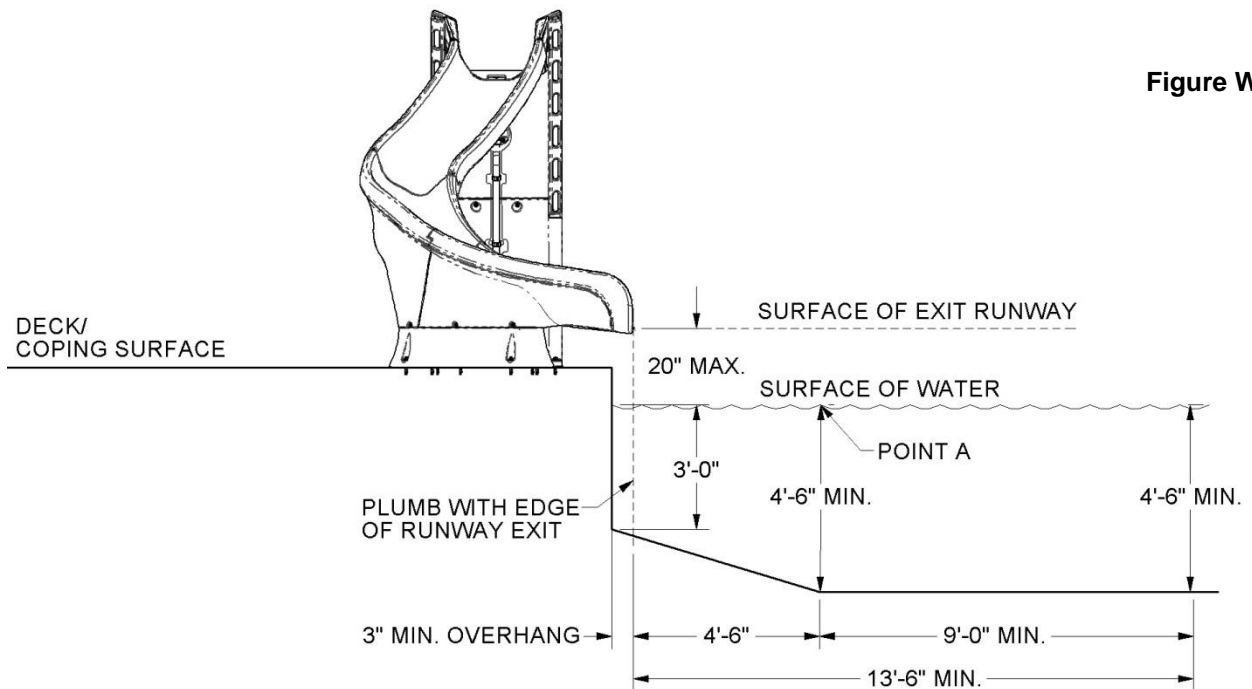

2. A minimum clearance area in front of the slide exit shall be maintained at all times as follows:

A. The minimum clearance distance on either side of the extended centerline of the slide runway shall not be less than 3'-6" at a point no less than 2'-6" from the exit lip of the slide and extending a distance of 13'-6" in front of the slide as shown in Figure X.

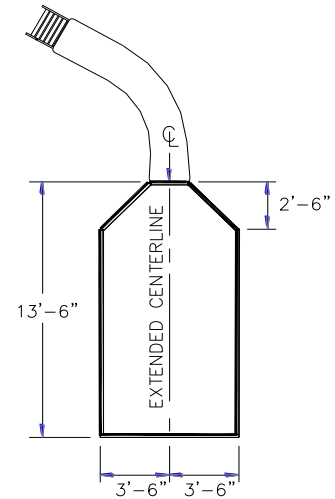

SLIDE
MINIMUM CLEARANCE AREA

B. The minimum clearance area in front of a properly installed diving board on an in-ground swimming pool is a minimum distance of 3'-6" on either side of the board's centerline as shown in Figure Y. (Pt.C) extends a minimum distance (C) from the tip end of the board as shown in Figure Y. The width distance (W) on either side of (Pt.C) is given in Table 1, below.

Table 1

Board Minimum Clearance Area		
Pool Type	(C) Dimension	(W) Dimension
I	14'-6"	5'-0"
II	14'-6"	6'-0"
III	16'-6"	6'-0"
IV	18'-6"	7'-6"
V	21'-0"	7'-6"

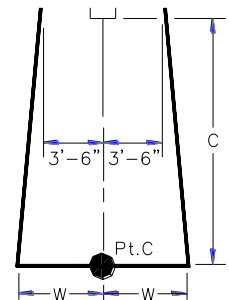

BOARD
MINIMUM CLEARANCE AREA

See Article 5 contained in "ANSI/APSP/ICC-5 2011 STANDARD FOR RESIDENTIAL INGROUND SWIMMING POOLS" and refer to Figure Y and Figure Z on this page for Minimum Water Envelope Dimensions AB, BC and Width (W) at (Pt.C).

(C) DIMENSION FOR BOARD = AB + BC
(W) DIMENSION FOR BOARD = WIDTH AT (PT.C)

- C. The minimum clearance area of a slide or diving board shall not intersect any coping or rope and float line as shown in Figure Z. The minimum clearance area of a slide or diving board may intersect each other provided that they are not used simultaneously.

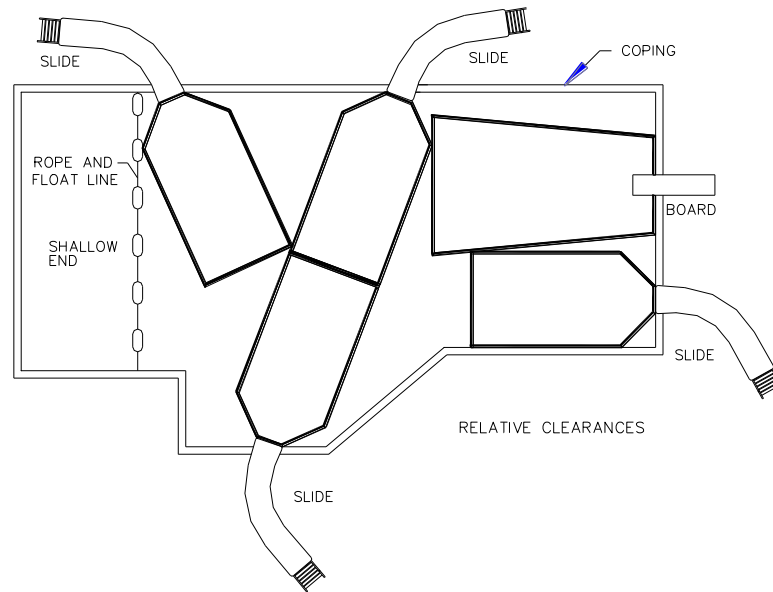

Figure Z