

NOTES:

1. EACH ROLLER HAS AN INTERNAL TUBULAR MOTOR POSITIONED AT EITHER END
2. EACH MOTOR REQUIRES A DEDICATED 120Vac 15A GFCI PROTECTED OUTLET. BY OTHERS
3. EACH MOTOR HAS A 3.0m ELECTRICAL CORD.
4. EQUOPOTENTIAL BONDING PER NEC AND LOCAL CODES. BY OTHERS

PLEASE RETURN SIGNED DRAWING TO SR SMITH IF APPROVED

DESCRIPTION: MOTORIZED BENCH REEL

MATERIAL:

PART NO.:

REV.

DRAWN BY:

DATE:

CHECKED BY:

DATE:



P.O. BOX 400 - 1017 S.W. BERG PARKWAY
CANBY, OREGON 97013
PHONE (503) 266-2231

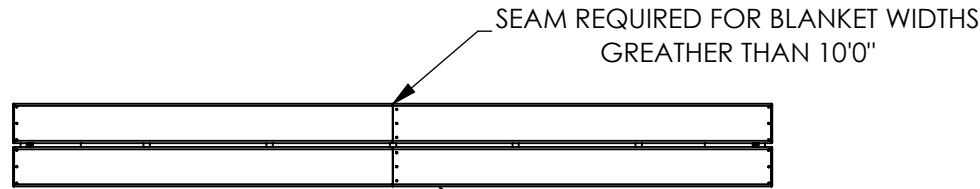

ALUMINUM BENCH SEAT

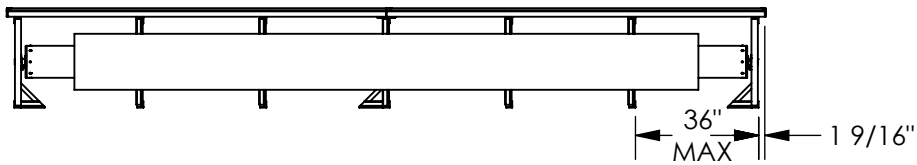
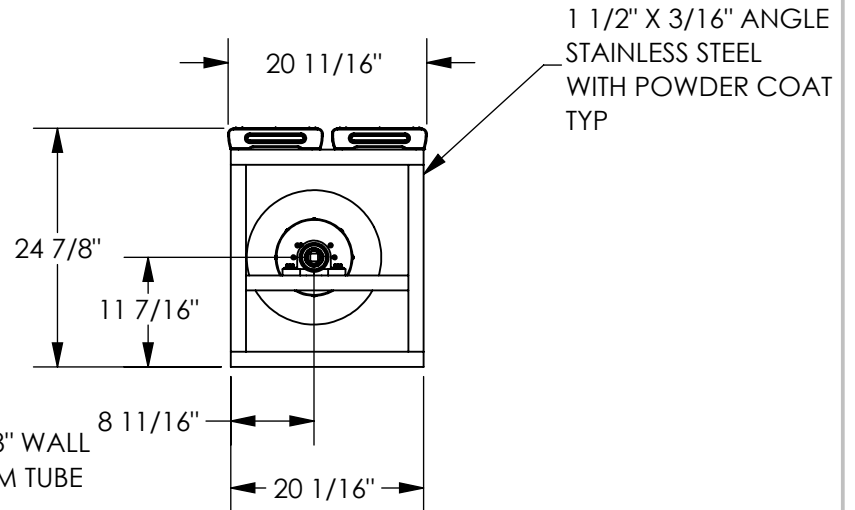
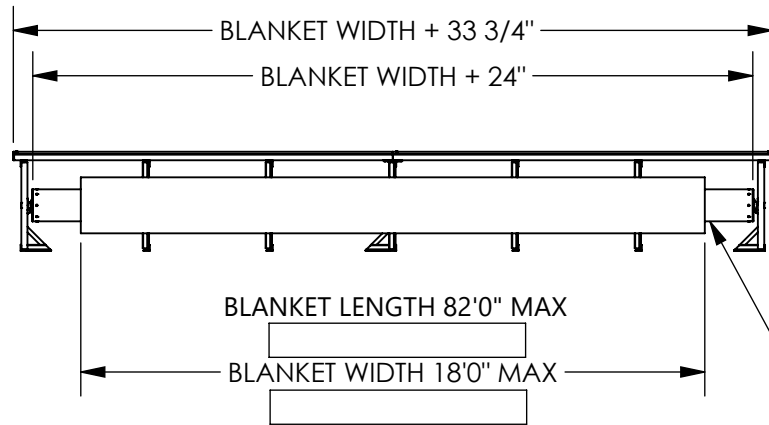

- NOTES:
 1. EQUOPOTENTIAL BONDING PER NEC AND LOCAL CODES. BY OTHER

PLEASE RETURN SIGNED DRAWING TO SR SMITH IF APPROVED

DESCRIPTION: 25M BENCH REEL	
MATERIAL:	
PART NO.:	REV.
DRAWN BY:	DATE:
CHECKED BY:	DATE:

SR SmithTM

P.O. BOX 400 - 1017 S.W. BERG PARKWAY
 CANBY, OREGON 97013
 PHONE (503) 266-2231

SIZE: A SCALE: 1:48 SHEET 1 OF 1

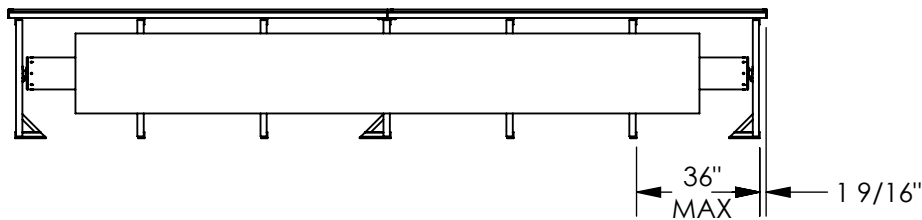
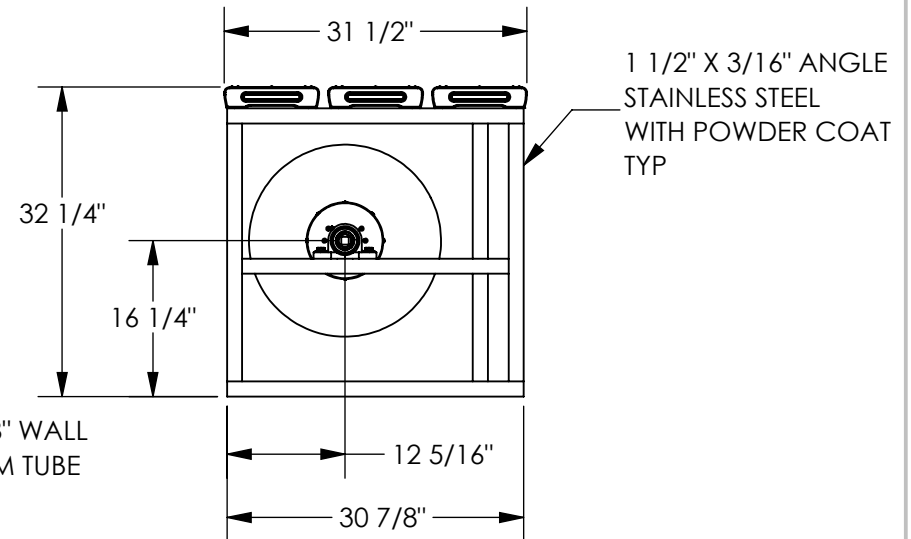
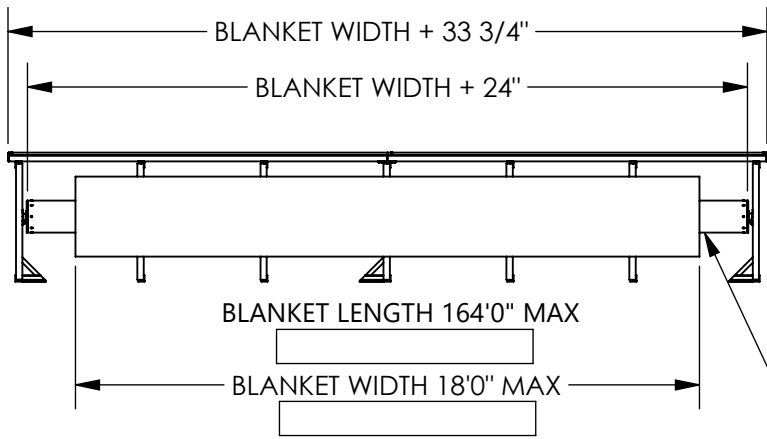
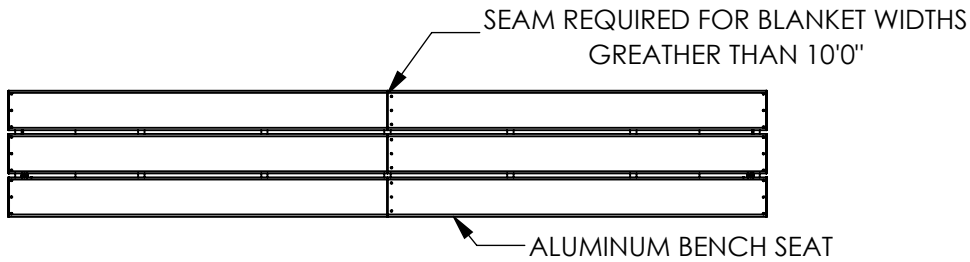

- NOTES:
- EQUOPOTENTIAL BONDING PER NEC AND LOCAL CODES. BY OTHER

PLEASE RETURN SIGNED DRAWING TO SR SMITH IF APPROVED

DESCRIPTION: 50M BENCH REEL

MATERIAL:

PART NO.:

REV.

DRAWN BY:

DATE:

CHECKED BY:

DATE:



P.O. BOX 400 - 1017 S.W. BERG PARKWAY
CANBY, OREGON 97013
PHONE (503) 266-2231

SIZE:

A

SCALE: 1:48

SHEET 1 OF 1