

Mod-Lite® LED Light

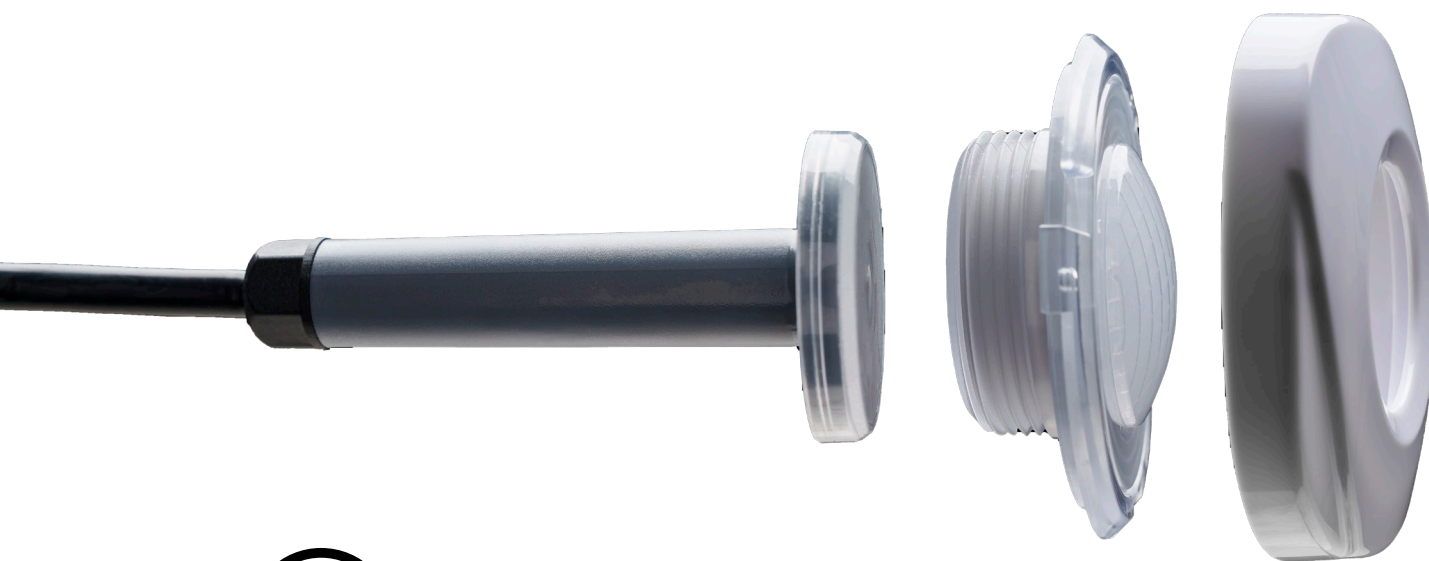

ETL LISTED
Conforms to UL STD 676
Certified to CSA C22.2 #89



Installation Instructions

Read all instructions before attempting to perform installation work.
Installation information applies to current and future Mod-Lite® and
Mod-Lite® MultiWhite models unless otherwise specified.

U.S. Patent No. 11,326,363

Contents

IMPORTANT INSTALLATION INFORMATION	4
OVERALL DIMENSIONS.....	5
WALL FITTING INFORMATION.....	6
INSTALLATION INSTRUCTIONS.....	7
SUCTION CUP TOOL	9
BASIC OPERATION FOR LED COLOR CHANGING LAMP	10
MULTIWHITE OPERATION	11
ADVANCED OPERATION VIA ACP	12
Mod-Lite® MAINTENANCE INSTRUCTIONS	12
WINTERIZATION	13

IMPORTANT INSTALLATION INFORMATION

Ensure that the electrical system for your pool conforms with all requirements of the National Electrical Code (NEC) and all relevant local codes and ordinances.

1. This 12VAC Underwater Light must be installed in accordance with the National Electrical Code by a Certified Electrician or a Qualified Pool Technician. **NOTE:** No Bonding Terminal is required on the forming shell since the fixture is an all plastic construction and complies with NEC article 680 Requirements
2. Waterproof conduit must be used from the S.R.Smith Mod-Lite® LED Light to the 'above ground' power supply equipment.
3. For supply connection, use only an isolating low voltage power supply with ungrounded output, evaluated for swimming pool use.
4. DO NOT CONNECT THIS 12VAC LIGHT DIRECTLY TO A 120VAC CIRCUIT – LIGHT WILL BE DAMAGED.
5. Fit your S.R.Smith Mod-Lite® LED Light/s as outlined in the following detailed installation instructions.
6. Except when the luminaire is installed in an area of the swimming pool that is not used for swimming and the lens is adequately guarded to keep any person from contacting it, the luminaire shall be installed in or on a wall of the pool, with the top of the lens opening not less than 100 mm (4 inches) below the normal water level of the pool.

NOTE: This light system is not intended to seal water out of the wall fitting. Water will eventually fill the conduit so be sure the conduit is watertight and terminates above ground.

CONNECT ONLY TO POWER SUPPLY INTENDED FOR USE WITH SUBMERSIBLE LUMINARIES

THIS DEVICE IS NOT INTENDED FOR USE WITH EMERGENCY EXITS

OVERALL DIMENSIONS

ELECTRICAL SPECIFICATION

Input Voltage: 12VAC

Color Change (RGB): 7 Watts max.

MultiWhite (WHIT): 9 Watts max.

COLOR CONTROL

Basic 12VAC mode (off/on control toggling)

S.R.Smith poolLUX™ ACP* compatible —
See pg. 10-11 for additional information

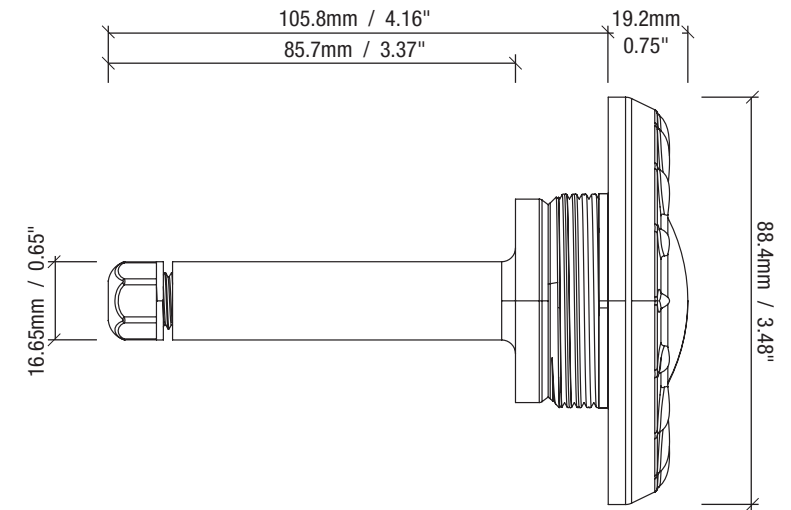

WALL FITTING INFORMATION

WALL FITTING FIT CHART 1.1

Brand	P/N	Type	Face-to-stop (internal) depth (inch)	Use with spacer
SR Smith	LNS-2G	gunite	0.89	No
SR Smith	LNS-2A	fiberglass	0.89	No
SR Smith	LNS-2V	vinyl liner	1.14	Yes
SR Smith	LNS-2GI	insider gunite (flangeless)	0.82 fitting only 0.89 plaster-to-stop required	No
Pentair	542404	gunite	0.89	No
Pentair	542402	gunite	0.93	No
Pentair	542414	fiberglass	0.91	No
Pentair	542429	vinyl liner	0.92	No
Pentair	86205100	vinyl liner	1.26	Yes
Hayward	SP1022S	gunite	0.92	No
Hayward	SP1022	gunite	0.94	No
Hayward	SP2023S	fiberglass	0.92	No
Hayward	SP1408A	vinyl liner	1.21	Yes

The fittings referenced above have been tested for positive fitment.

Fittings not referenced above but exhibit a face-to-stop depth range of **0.89" – 1.26"** can be used and should have similar installation characteristics (Spacer/No Spacer Required) to the tested fittings.

Fittings with a face-to-stop depth of **1"** or greater, the supplied spacer may be needed.

Fittings with less than **0.89" (22.6mm)** face-to-stop (internal) depth are not recommended.

Due to manufacturing tolerances of white goods, even items from the chart may be tight in the diameter of the threaded area near the stop (See **Illustration A**). Fortunately, this is easily addressed if the face to internal stop depth is between **0.89" – 1.25"**. If the internal diameter of the wall fitting is tight, simply using a fine to medium grit sand paper to knock down the thread height in the lower threaded portion (last 2-3 threads) near the stop will provide the needed clearance – heavy sanding is not required.

DO NOT sand completely through the threads.

DO NOT sand the upper threads near the front face of the fitting.

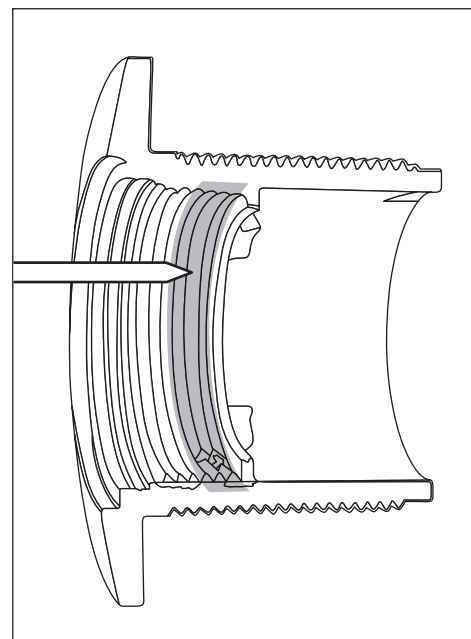

Illustration A

INSTALLATION INSTRUCTIONS

FOLLOW PROPER WIRING PRACTICES IN ACCORDANCE WITH ALL LOCAL REGULATORY REQUIREMENTS.

- Per NEC Article 680.23 (5) lights are to be installed in no less than **18" (450mm)** below the normal water level unless the luminaire is listed and identified for use at lesser depths. S.R.Smith lights are listed and identified for use at depths no less than 4" (100mm) below the normal water level. Max depth is 36" below water surface. All depth measurements are from the normal water level to the top of the Luminaire lens.
- Fit an S.R.Smith LNS-2G, LNS-2A, LNS-2V or similar (see **Chart 1.1**), **1½"** pool wall fitting into the pool wall at the selected location. Watertight PVC conduit must be used from the wall fitting to the above water/ground level conduit termination on the equipment or supply side of the 12V AC line. Please refer to the Typical Installation illustration below.
- To confirm that the wall fitting will accept the Power Coupler to the full depth, simply insert the head of the Power Coupler into the wall fitting from the front, pool side (**Illustration B**). If it reaches the internal stop, proceed to step 5. If there is interference from the Internal Diameter of the threads, go to step 4.
- Assuming that the fitting you are working with falls within the acceptable range of measurements in **Chart 1.1**, the diameter interference is most likely due to injection tolerances of the fitting itself. This can be addressed with the careful application of some medium grit sand paper or a sanding drum on a rotary tool – see **Illustration A**, page 6. Carefully and gradually use the sanding device to take some material off of the circumference of the threads in the affected area. Do Not sand more than ¼ of the thread height or you risk sanding through the threads.

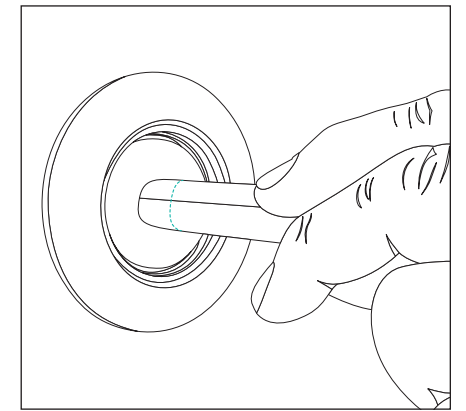

Illustration B

Take your time and go gradually – test often (step 3) until Power Coupler fits snugly at the internal stop.

- Referring to the **chart 1.1** on page 6, check the face-to-stop distance on the wall fitting to be used. If the distance is between **0.89 - 1.0"** the black foam rubber spacer on the Power Coupler is not required and should be cut off with scissors. If the face-to-stop distance is greater than **1.0"** the black foam rubber spacer should remain on the Power Coupler.

Scan this code to see how easy it is to install Mod-Lite®



6. Fit the Power Coupler module cord end first into the 1½" wall fitting and carefully pull most of the waterproof supply cable through to the power equipment. ONLY pull the cord until the face of the Power Coupler is flush with the front face of the wall fitting (see **Illustration C**), DO NOT PULL FURTHER.
7. Attach the desired trim plate to the Mod-Lite® LED lamp module by lining up the 3 tabs on the plate to the 3 notches in the lamp module. Holding the lamp module by the threaded section, twist the trim plate clockwise until it reaches the end of the rotational adjustment range just under ¼ turn – see **Illustrations D & E**.
8. Holding the LED lamp module by the trim plate, position the threaded portion at the mouth of the wall fitting. Thread the lamp assembly into the wall fitting by applying gentle but firm pressure while twisting clockwise until secure. Be sure to not cross thread the lamp into the wall fitting. The depth position of the Power Coupler will be determined by the threaded position of the lamp module. If binding occurs before the lamp is bottomed on the wall fitting face, STOP. Unthread the lamp module and inspect the fitting to be sure that the Power Coupler can fully seat on the internal stop in the fitting AND that the stop is at least 0.89" deep (see **Chart 1.1**), AND that the wall fitting threads are in good shape. DO NOT Over-tighten the light as damage may occur.
9. Connect the red / black wire conductors of the S.R.Smith Mod-Lite® to an approved, low voltage, class 2, Magnetic Type Power Source that complies with UL379 or an S.R.Smith poolLUX™ brand power supply as required by NEC or relevant local codes and ordinances.
10. The Mod-Lite® is now ready for use and will operate similar to any of the SR Smith family of LED lights.

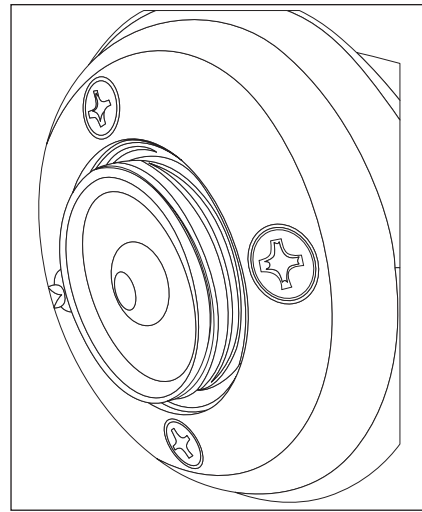

Illustration C

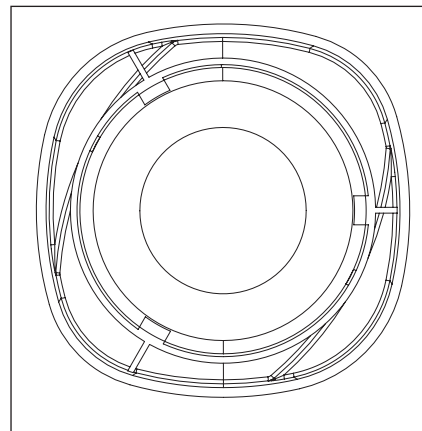

Illustration D

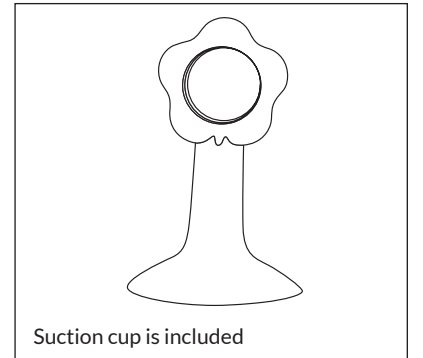

Illustration E

SUCTION CUP TOOL

The blue Suction Cup tool is for extraction of the Power Coupler in the event the Power Coupler needs to be repositioned or removed. It is intended to grab the large flat face of the Power Coupler and bring it towards the opening of the wall fitting. If the cord has not been pulled back fully as outlined on step 6, on page 8, this will allow full access to the Power Coupler. To extract the Power Coupler:

1. Wet or moisten the suction cup side of the tool.
2. Use a rag to wipe out any debris from the face of the Power Coupler.
3. Place the suction cup side of the tool, centered into the wall fitting and place it against the face of the Power Coupler – push gently.
4. Pull on the tool to bring the Power Coupler out to the opening of the wall fitting.
5. To remove the tool, simply slide the suction cup off sideways from the Power Coupler. Place the tool in secure storage for future use.



Suction cup is included

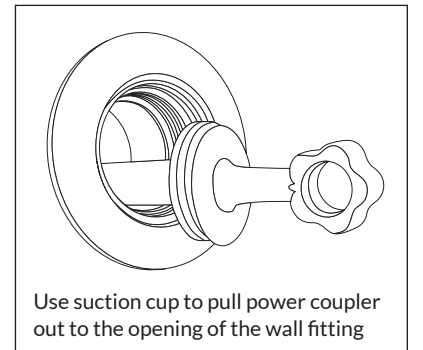

Use suction cup to pull power coupler out to the opening of the wall fitting

*Approved 12VAC Class 2 Power Source
See #9 on previous page

TYPICAL INSTALLATION

1.5" watertight, underground PVC conduit back to 12VAC transformer.
All fittings should be glued and watertight.

*Minimum of 3.5" of straight, 0.75" or greater conduit behind the wall fitting required prior to any bends or turns.

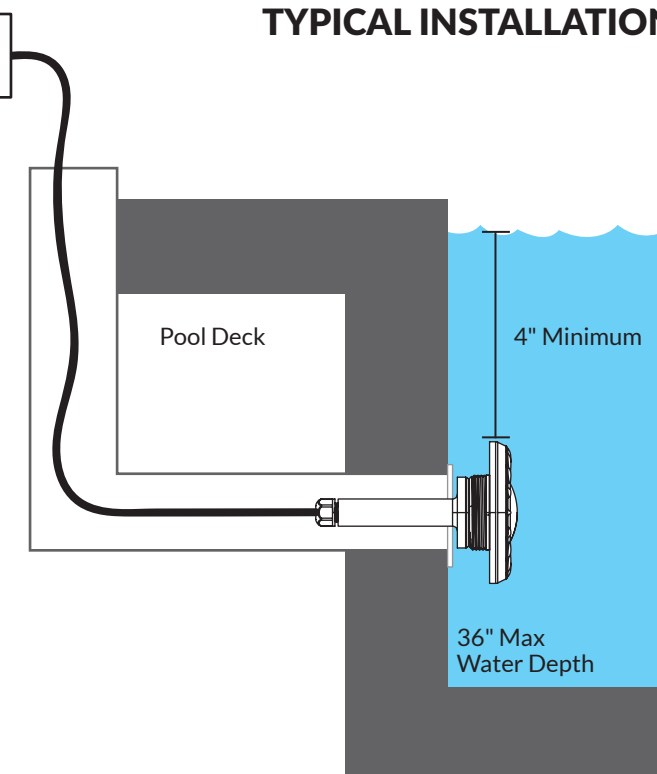

Luminaire is listed and identified for use at 4" or more below the normal water level of the pool.

Optimal lighting coverage may be found at 10-12" below water level. Maximum depth is 36"

BASIC OPERATION FOR LED COLOR CHANGING LAMP (RGB)

When connected to an approved, 12VAC, UL379 listed power supply – The S.R.Smith Mod-Lite® LED color changing light uses simple ‘off / on’ power switching to control the basic, pre-defined color modes with memory function.

Memory

The memory function remembers the last color setting. For example, if the light was last used in the blue mode, the next time the light is turned on it will be blue mode.

Color Mode Selection

The LED will turn on to the color in memory. To move to the next color mode, quickly (within one second or faster) toggle the power to the lights ‘OFF / ON’.

Advance through the modes until the desired mode is selected. The modes will cycle 1,2,3,4,5,6,7,8, then cycle back to 1. See table for details.

COLOR MODE SELECTION GUIDE	
Mode 1	Soft Color Change
Mode 2	White
Mode 3	Blue
Mode 4	Green
Mode 5	Red
Mode 6	Amber
Mode 7	Magenta
Mode 8	Flash Color Change

Color Sync Reset

To synchronize all lights on the system including older *Fiberstars LED Series Pool lights, you must use the following sequence:

1. Turn lights ‘ON’ to confirm the color modes are out of sync.
2. Turn lights ‘OFF’ for 5 seconds or more.
3. Toggles lights ‘ON’ / OFF’ three times within three seconds – must end in ‘OFF’ condition
4. Leave lights in ‘OFF’ condition for 5 seconds.
5. Turn lights ‘ON’ and confirm that all lights are in mode #1, Soft Color Change

* Older Fiberstars LED lights can synchronize with the newest generation lights ONLY if they have their DIP switches in their default, ‘All Down’ position. In a mixed environment, the Color Sync Reset will need to be performed each time the lights are used and color synchronization is desired.

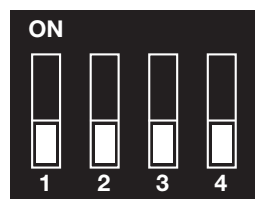

BASIC OPERATION FOR LED MULTIWHITE CHANGING LAMP (WHITE)

Like Mod-Lite, when Mod-Lite MultiWhite is connected to an approved, 12VAC, UL379 listed power supply, uses simple ‘off / on’ power switching to control the basic, pre-defined color temperatures with memory function.

Memory

The memory function remembers the last color setting. For example, if the light was last used in the Cool White mode, the next time the light is turned on it will be Cool White mode.

Color Mode Selection

The LED will turn on to the color temperature in memory. To move to the next color temperature, quickly (within one second or faster) toggle the power to the lights ‘OFF / ON’.

Advance through the modes until the desired mode is selected. The modes will cycle 1,2,3, then cycle back to 1. See table for details.

COLOR MODE SELECTION GUIDE	
Mode 1	Warm White
Mode 2	Classic White
Mode 3	Cool White

White Mode Reset

To synchronize all MultiWhite lights on the system, you must use the following sequence:

1. Turn lights ‘ON’ to confirm the color modes are out of sync.
2. Turn lights ‘OFF’ for 5 seconds or more.
3. Toggles lights ‘ON’ / OFF’ three times within three seconds – must end in ‘OFF’ condition
4. Leave lights in ‘OFF’ condition for 5 seconds.
5. Turn lights ‘ON’ and confirm that all lights are in mode #1, Warm White

THERMAL PROTECTION

This light is equipped with a thermal protection circuit built into the LED lamp assembly. If the circuit detects that the lamp assembly is getting too hot for a given environment, it will automatically reduce the brightness in increments until the lamp remains below the thermal threshold. If this condition occurs, it may or may not be noticeable by the human eye and is a normal function, not a sign of malfunction or failure.

ADVANCED OPERATION VIA ACP

Advance Control Protocol (ACP), available exclusively with S.R.Smith's poolLUX Premier control, provides dimming and custom color control through a dedicated color remote control. S.R.Smith Mod-Lite®, kēlo®, Fiberglass®, Treo Micro® LED lights and 2015 or later water features are ACP compatible. Note that Mod-Lite MultiWhite does not support ACP functionality.

Mod-Lite® MAINTENANCE INSTRUCTIONS

Depending on water chemistry, installation environment and usage patterns, the Mod-Lite® may require occasional maintenance for consistent performance. Maintenance may be timed to coincide with seasonal closing and opening of pools. For pools that operate year-round, S.R. Smith recommends that maintenance should be performed once a year.

1. Remove Lamp Module by unscrewing the Lamp Module from the wall fitting. It is OK to use the trim plate for grip and leverage, just keep the tabs engaged in the track by pushing the trim plate on towards the Lamp Module.
2. Use a damp cloth to wipe the back of the Lamp Module clean from any dirt or debris that may have settled. Do the same to the front (pool side) of the Power Coupler inside the wall fitting. The Power Coupler does not need to be removed to perform this step.
3. Use the suction cup tool to pull the Power Coupler flush with the face of the wall fitting. Remove the suction cup tool.
4. Reattach the trim plate to the Lamp Module by lining up the 3 tabs of the trim plate to the notches in the Lamp Module and turning the trim plate clockwise to engage.
5. Holding the LED lamp module by the trim plate, position the threaded portion at the mouth of the wall fitting. Thread the lamp assembly into the wall fitting by applying gentle but firm pressure while twisting clockwise until secure. Be sure to not cross thread the lamp into the wall fitting. The depth position of the Power Coupler will be determined by the threaded position of the lamp module. If binding occurs before the lamp is bottomed on the wall fitting face, STOP, remove the Lamp Module, inspect for thread damage and carefully try again.

WINTERIZATION

NOTE – If water is trapped in conduit, damage may occur from freeze expansion.

1. Swimming Pools may or may not be drained completely. If not drained completely, the water level should be lowered below the S.R.Smith Mod-Lite LED Light and make sure that all water is drained from the wall fitting and conduit by removing the Lamp Module and letting the water drain out, then replacing the Lamp Module. This will require that the water level remain below the wall fitting level for the duration of the 'winter' season.
2. Alternatively, the S.R.Smith Mod-Lite LED Lamp Module may be removed completely, the conduit purged of all water, and the custom 1½" Threaded Hole utility plug with triple density, PTFE thread sealing tape may be used to close the wall fitting. As there are differences in wall fitting types in both new or used condition, the wall fitting should be inspected to determine the suitability of the custom 1½" Threaded Hole utility plug and its ability to seal the fitting.

DO NOT USE a standard 'Off the shelf' threaded plug part as the deeper depth may damage the Power Coupler.

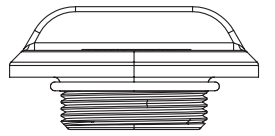
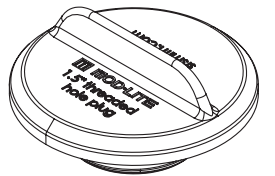
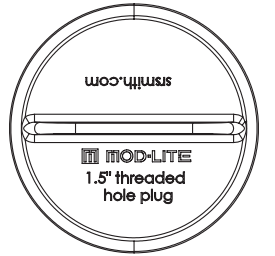

Part # MLED-THP

WARRANTY INFORMATION

For Lighting product warranty information and details, please visit our website:
srsmith.com/warranty

Instrucciones de instalación disponibles en español en srsmith.com.

Scan this code to
see how easy it is
to install Mod-Lite®



Questions?

Contact One of Our Dedicated Lighting Specialists: **1-800-824-4387** x4012 or x2282



S.R.Smith, LLC
800.824.4387
srsmith.com