



# **SPLASH!™ 300 POOL LIFT – CEC COMPLIANT MODELS**

## **OWNER'S MANUAL & MAINTENANCE PROCEDURES**









**S.R. SMITH, LLC**  
CORPORATE HEADQUARTERS  
P.O. Box 400 • 1017 S.W. Berg Parkway  
Canby, Oregon 97013 USA  
Phone (800) 824 4387 • Fax (503) 266 4334

## DECK PROFILE SHEET CONFIRMATION

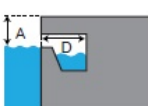
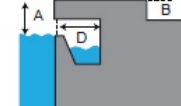
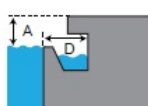
Aquatic access lifts are application specific. A completed Deck Profile Sheet helps to ensure the lift purchased for the application will work in accordance to ADA guidelines. S.R. Smith reviews all submitted Deck Profile Sheets as a service to our customers, free of charge. Before installing the pool lift, the installer must review and confirm the information provided on the Deck Profile Sheet. If the description of the application does not match the installation site, a new Deck Profile Sheet must be completed and submitted to S.R. Smith.

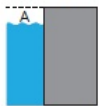
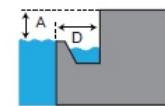
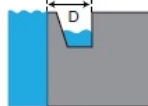
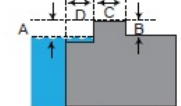
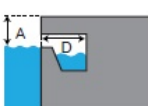
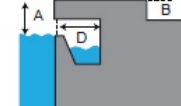
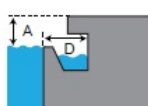
**NOTE: FAILURE TO COMPLETE AN ACCURATE DECK PROFILE SHEET MAY RESULT IN THE LIFT NOT MEETING ADA COMPLIANCE GUIDELINES.**

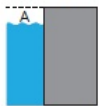
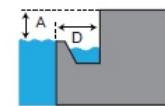
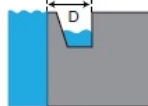
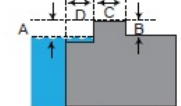
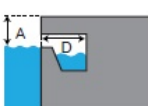
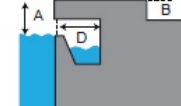
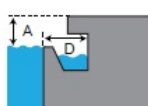
To complete the Deck Profile Sheet online, visit [www.srsmith.com/liftprofile](http://www.srsmith.com/liftprofile), contact Customer Service at (800) 824-4387 or email [customercare@srsmith.com](mailto:customercare@srsmith.com).

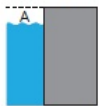
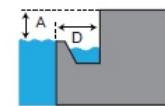
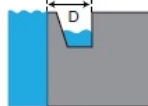
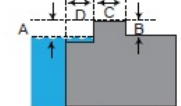
 deck profile sheet <b>POOL LIFT*</b>																			
<small>*Deck profile sheet must accompany your pool lift order</small>																			
1. Preferred Lift: <input type="checkbox"/> PAL <input type="checkbox"/> PAL2 <input type="checkbox"/> Splash! <input type="checkbox"/> Splash! 300 <input type="checkbox"/> aXs <input type="checkbox"/> multiLift <input type="checkbox"/> ML300																			
2. Gutter Configuration: <table border="0" style="width: 100%;"> <tr> <td><input type="checkbox"/> Fully recessed gutter</td> <td><input type="checkbox"/> Fully recessed gutter w/parapet</td> <td><input type="checkbox"/> Partially recessed gutter</td> <td><input type="checkbox"/> Bull Nose Coping</td> </tr> <tr> <td></td> <td></td> <td></td> <td></td> </tr> <tr> <td><input type="checkbox"/> Standard backyard pool</td> <td><input type="checkbox"/> Rollout gutter</td> <td><input type="checkbox"/> Flush gutter and deck w/ or w/o bullnose</td> <td><input type="checkbox"/> Florida Rollout w/curb</td> </tr> <tr> <td></td> <td></td> <td></td> <td></td> </tr> </table> <p style="font-size: small;">If none of the images above match your gutter configuration, please draw the shape on a separate piece of paper and attach.</p>		<input type="checkbox"/> Fully recessed gutter	<input type="checkbox"/> Fully recessed gutter w/parapet	<input type="checkbox"/> Partially recessed gutter	<input type="checkbox"/> Bull Nose Coping					<input type="checkbox"/> Standard backyard pool	<input type="checkbox"/> Rollout gutter	<input type="checkbox"/> Flush gutter and deck w/ or w/o bullnose	<input type="checkbox"/> Florida Rollout w/curb						
<input type="checkbox"/> Fully recessed gutter	<input type="checkbox"/> Fully recessed gutter w/parapet	<input type="checkbox"/> Partially recessed gutter	<input type="checkbox"/> Bull Nose Coping																
																			
<input type="checkbox"/> Standard backyard pool	<input type="checkbox"/> Rollout gutter	<input type="checkbox"/> Flush gutter and deck w/ or w/o bullnose	<input type="checkbox"/> Florida Rollout w/curb																
																			
3. Facility Type (check one): <input type="checkbox"/> Health Club <input type="checkbox"/> Hospitality <input type="checkbox"/> Public Pool <input type="checkbox"/> Residential <input type="checkbox"/> Commercial																			
4. Deck (check one): <input type="checkbox"/> New Construction <input type="checkbox"/> Pre-existing																			
5. Deck Material (check one): <input type="checkbox"/> Concrete <input type="checkbox"/> Pavers																			
6. Distance from pool deck to water line (A): _____																			
7. Height of curb (B): _____																			
8. Width of curb (C): _____																			
9. Width of gutter (D): _____																			
10. Bull Nose Radius (E): _____																			
11. Decorative stone setback: _____																			
12. Is your pool located on the ground level? <input type="checkbox"/> Yes <input type="checkbox"/> No																			
<p style="font-size: x-small;"> <input type="checkbox"/> <b>POOL</b> Check this box to confirm that you have verified the location of the lift will meet the ADA Clear Deck Space Requirement (1009.2.3):                      "On the side of the seat opposite the water, a clear deck space shall be provided parallel with the seat. The space shall be 36" wide minimum and shall extend forward 48" minimum from a line located 12" behind the rear edge of the seat."                 </p>																			
<p style="font-size: small;"> <b>Note:</b> Pool lifts are application specific. Please provide accurate measurements for your pool in the space provided. S.R. Smith will confirm that the lift selected will meet the location and installation requirements based on the ADA Design Standards (2010) or suggest an alternative lift that will meet the requirements. S.R. Smith bears no responsibility due to misapplication of a lift without a completed Deck Profile Sheet on record.                 </p>																			
<b>Fax this completed form to 503.266.4334, email to <a href="mailto:lifts@srsmith.com">lifts@srsmith.com</a>, or complete the form online at <a href="http://www.srsmith.com/liftprofile">www.srsmith.com/liftprofile</a>. Call toll free 800.824.4387</b>																			
<table border="0" style="width: 100%;"> <tr> <td style="width: 50%;">Name of Distributor LIR Will Be Purchased From</td> <td style="width: 25%;">City</td> <td style="width: 25%;">State</td> </tr> <tr> <td colspan="3" style="border: 1px solid black; height: 20px;"></td> </tr> <tr> <td>Your Name</td> <td>Email</td> <td>Phone</td> </tr> <tr> <td colspan="3" style="border: 1px solid black; height: 20px;"></td> </tr> <tr> <td>Property or Project Name</td> <td colspan="2">PO Number</td> </tr> <tr> <td colspan="3" style="border: 1px solid black; height: 20px;"></td> </tr> </table>		Name of Distributor LIR Will Be Purchased From	City	State				Your Name	Email	Phone				Property or Project Name	PO Number				
Name of Distributor LIR Will Be Purchased From	City	State																	
Your Name	Email	Phone																	
Property or Project Name	PO Number																		
<b>S.R. Smith Use Only</b> APPROVAL# _____ <table border="0" style="width: 100%;"> <tr> <td><input type="radio"/> PAL</td> <td><input type="radio"/> PAL HI/LO</td> <td><input type="radio"/> PAL SPA</td> <td><input type="radio"/> PAL2</td> </tr> <tr> <td><input type="radio"/> SPLASH</td> <td><input type="radio"/> SPLASH HI/LO</td> <td><input type="radio"/> SPLASH ER</td> <td><input type="radio"/> SPLASH ER HI/LO</td> </tr> <tr> <td><input type="radio"/> SPLASH 300</td> <td><input type="radio"/> SPLASH W/ROUND POST</td> <td><input type="radio"/> AXS</td> <td><input type="radio"/> MULTILIFT</td> </tr> <tr> <td></td> <td></td> <td></td> <td><input type="radio"/> ML300</td> </tr> </table>		<input type="radio"/> PAL	<input type="radio"/> PAL HI/LO	<input type="radio"/> PAL SPA	<input type="radio"/> PAL2	<input type="radio"/> SPLASH	<input type="radio"/> SPLASH HI/LO	<input type="radio"/> SPLASH ER	<input type="radio"/> SPLASH ER HI/LO	<input type="radio"/> SPLASH 300	<input type="radio"/> SPLASH W/ROUND POST	<input type="radio"/> AXS	<input type="radio"/> MULTILIFT				<input type="radio"/> ML300		
<input type="radio"/> PAL	<input type="radio"/> PAL HI/LO	<input type="radio"/> PAL SPA	<input type="radio"/> PAL2																
<input type="radio"/> SPLASH	<input type="radio"/> SPLASH HI/LO	<input type="radio"/> SPLASH ER	<input type="radio"/> SPLASH ER HI/LO																
<input type="radio"/> SPLASH 300	<input type="radio"/> SPLASH W/ROUND POST	<input type="radio"/> AXS	<input type="radio"/> MULTILIFT																
			<input type="radio"/> ML300																

**TABLE OF CONTENTS**

**Splash! 300 (300-3000-BC)/, Splash!300 Hi/Lo (350-3000-BC), Splash!300 Spa (375-3000-BC),  
 Splash! W/Round Anchor Stem (300-0000R-BC)**

DECK PROFILE SHEET CONFIRMATION..... 2  
 INTRODUCTION..... 4  
 INTENDED LIFT USER ..... 4  
 WARNINGS AND SAFETY SUMMARY ..... 5  
 PRODUCT OVERVIEW ..... 6  
 SPLASH! 300 - PRODUCT COMPONENTS ..... 7  
 COMPONENT DESCRIPTION ..... 7  
 UNPACKING & ASSEMBLY INSTRUCTIONS..... 12  
 POOL DECK INSTALLATION FOR THE SPLASH! LOCKING ANCHOR ..... 14  
 USING THE Splash! LIFT ..... 15  
 TRANSFERRING ..... 16  
 STANDARD ACCESSORIES/OPTIONAL ACCESSORIES..... 17  
 MAINTENANCE and CLEANSING ..... 18  
 TROUBLE SHOOTING ..... 19  
 LONG-TERM STORAGE ..... 20  
 WARRANTY INFORMATION ..... 20  
 SPECIFICATIONS ..... 21  
     1. Dimensions/Capacity ..... 21  
     2. Actuator ..... 21  
     3. Motor..... 21  
     4. Battery ..... 21  
     5. Range of Motion ..... 21  
     6. Noise..... 21  
     7. Materials and Finish ..... 21  
 PARTS LIST (SPLASH! 300)..... 22  
 PARTS LIST (SPLASH! Hi/Lo or SPA) ..... 23  
 APPENDIX - A ..... 24  
 APPENDIX - B ..... 24

# READ THESE INSTRUCTIONS IN THEIR ENTIRETY BEFORE BEGINNING INSTALLATION

## INTRODUCTION

The purpose of this document is to provide information relating to the safe operation, care, and maintenance of the **Splash! 300 Pool Lift**.

## INTENDED LIFT USER

All of S.R. Smith's lifts have been designed to assist anyone who has problems entering or exiting a swimming pool or spa - the only restriction is that the User does not exceed the weight limit of the product (300 lb/136 kg). It is the responsibility of the lift Owner to ensure that the correct safety procedures have been put in place and a risk assessment carried out. If a User is mentally challenged or has severe physical disabilities these issues must be taken into account to determine the number of persons required to complete the transfer onto the seat and the number of persons required to be in the water, ready to receive the User. The seat belt must be attached to the seat and fully fastened and used during each transfer.

Our goal is to provide our customers with the most advanced and innovative designs offering exceptional quality at affordable prices. All of our lifts meet the specifications set forth by the Access Board - ADAAG 2004 (US only), Medical Device Directive, 93/42/EEC, RoHS2 Directive 2011/65/EU, EN 50581:2012 and ISO10535:2006 including repeating the lifting cycle of the hoist (lift) for a total of 11,000 cycles. The lift system and AC powered battery charger complies with EN60601-1-2, 2007/03.

Model / Product No. \_\_\_\_\_  
Product Name \_\_\_\_\_



**S.R. Smith, LLC**  
PO Box 400  
1017 SW Berg Parkway  
Canby, Oregon 97013 USA  
Phone: 503-266-2231  
Fax: 503-266-4334  
www.srsmith.com  
Made in USA

SN S



24 VDC

US Patent No. 5,790,995

Splash! and the Splash! Logo and LiftOperator are registered trademarks of S.R. Smith, LLC.



## WARNINGS AND SAFETY SUMMARY

**DANGER – FAILURE TO FOLLOW THESE WARNINGS, INSTRUCTIONS AND THE OWNER'S MANUAL MAY RESULT IN SERIOUS INJURY OR DEATH**

### **WARNING**

- **ADULT USE ONLY** – Use by children with adult supervision only. Only persons healthy enough for water activities should use the SPLASH!. Users should consult with their physician to determine if water activities are appropriate for the User.
- Seat belt is to be used at all times during user transfer.
- **NO JUMPING/DIVING/CLIMBING** – Do not jump/dive from or climb on lift.
- Limit for use is **ONE PERSON** weighing less than the maximum weight limit of – 400lbs (181kg) for the SPLASH! And SPLASH! Hi/Lo and 300lbs (136kg) for the SPLASH! 300 and SPLASH! Extended Reach. Use only for transfer of user not as a hoist or crane.
- **PINCH/CRUSH HAZARD** – Always keep hands and fingers clear of lift arms during use.

### **CAUTION**

- **BATTERY CHARGE LEVEL** – Check Battery Level before each use. Battery must show GREEN >50% charge level before use. When YELLOW <50% charge level is shown the battery must be fully charged before use. When RED <25% charge level is shown the lift must not be used and the battery must be fully charged before use.
- **DAMAGE MAY RESULT** – Do not use the seat or seat frame to move or position the Splash!.
- **DAMAGE MAY RESULT** - Do not allow excessive moisture to collect in the battery case, it can affect battery and lift performance and could lead to battery failure and/or the lift failing to operate.

	<b>WARNING</b>	<b>WARNING</b>
	<b>Pinch Points.</b> Moving part can crush or cut. <b>KEEP CLEAR.</b>	<b>LIMIT FOR USE IS ONE PERSON WEIGHING LESS THAN THE MAXIMUM WEIGHT LIMIT OF 300 lbs (136 kg)</b>

### ADA GUIDELINE SUMMARY\* (USA Only)

#### 1009.2.1 Pool Lift Location

Pool lift shall be located where the water level does not exceed 48". If entire pool water level exceeds 48", place pool lift where convenient.

#### 1009.2.2 Seat Location

In the raised position, the centerline of the seat shall be located over the deck a minimum of 16" from the edge of the pool.

#### 1009.2.3 Clear Deck Space

On the side of the seat opposite the water; a clear deck space shall be provided parallel with the seat. The space shall be 36" wide minimum and shall extend forward 48" minimum from a line located 12" behind the rear edge of the seat.

#### 1009.2.4 Seat Height

The lift shall stop at 16" – 19" measured from the deck to the top of the seat surface when in the loading position.

#### 1009.2.8 Submerged Depth

The lift shall submerge the seat a minimum of 18" below the stationary water level.

\*Compliance with ADA is the responsibility of the pool owner. Visit [www.ada.gov](http://www.ada.gov) for complete guidelines.

## THE SPLASH! AQUATIC LIFT SYSTEM

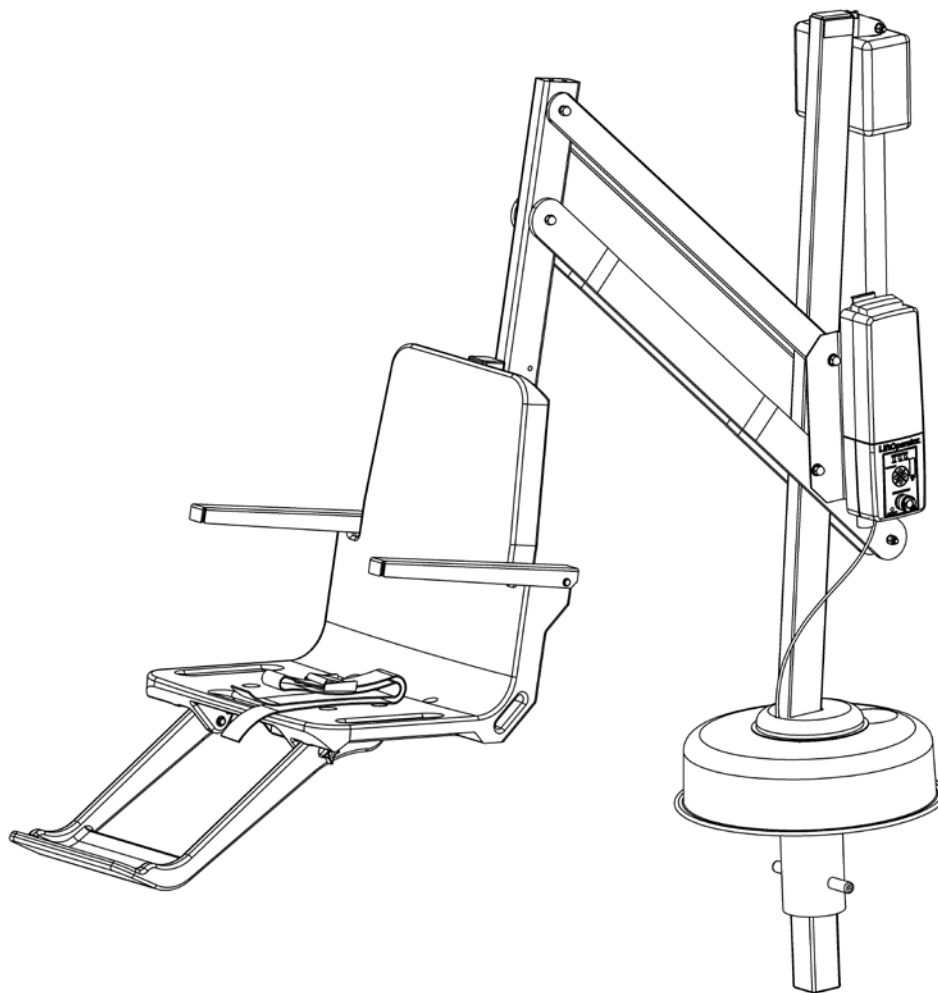

**STANDARD SPLASH! 300**

### PRODUCT OVERVIEW

The Splash! Aquatic Lift is a semi-portable lift system designed so that individuals with disabilities and mobility impairments can have universal access to any type of swimming pool or spa. The Splash! is powered by a 24 volt rechargeable battery. The lifting motion is provided by a screw driven electronic actuator and an electronic gear motor provides the turning motion. S.R. Smith has designed the safest possible lift system, following all instructions in the owner's manual, and all product labels is necessary to achieve safe, reliable and proper performance of the lift and avoid injury. This design ensures consistent safe operation and minimizes service problems. The Splash!300 is available in a Spa version, for use with above-ground pools and spas; and a Hi/Lo version, for facilities with both above-ground and ground level pools and spas. Although the Splash! must be operated from a stationary deck anchor it can be transported using the Splash! Caddy. The Caddy is designed to facilitate lifting the Splash! out of the deck anchor and also serves as a storage rack when the lift is not needed. The maximum lift capacity for the Splash!300 is 300 lb/136 kg. Only persons healthy enough for water activities should use the Splash!. Users should consult with their physician to determine if water activities are appropriate for the User.

## SPLASH! 300 - PRODUCT COMPONENTS

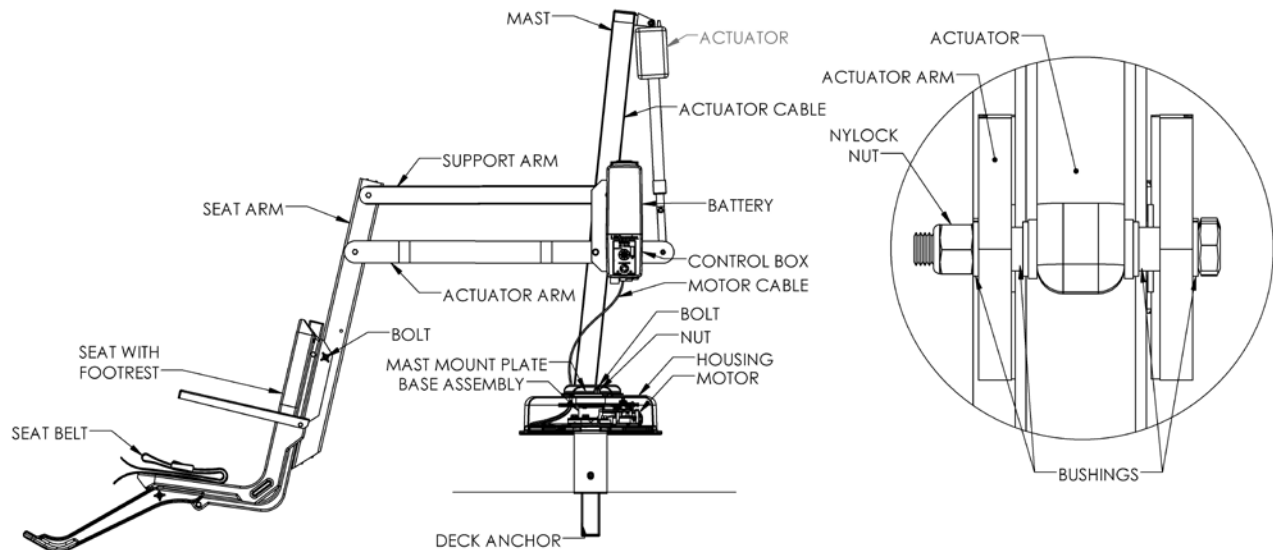

**SPLASH! 300**

### COMPONENT DESCRIPTION

The Base Assembly is made up of several components described below:

**Base Assembly** - Mounts to the pool deck or concrete boat dock.

**Base Insert Stem** - Slides into the anchor sleeve that is installed on the pool deck or dock.

**Housing** - ABS plastic cover shields base assembly components from weather. Must be in place prior to installing the mast assembly.

**Attachment Cover** - Slides down over housing to cover hardware (bolts and washers).

**Control Box** - The LiftOperator unit controls all lift operations identical to the user hand set. Three cables connect to the bottom of the Control Box to enable operation of the lift. The largest connector is for the hand control. Connector # 1 is for the motor cable (red stripe). Connector # 2 is for the actuator cable (green stripe).

#### Touchpad Control –

The touchpad control arrow keys can be used in the event that the hand control is out of reach or fails. Simply press and hold the arrow for the desired action for one movement at a time – Up, Down, Left, Right Releasing the Arrow stops movement.



**CONNECTOR 1  
(MOTOR CABLE)**

**CONNECTOR 2  
(ACTUATOR CABLE)**

### Battery Level LED Indicators –

The Battery Level LED Indicators show battery charge levels. The LED's will illuminate when either the touchpad control or the hand control is activated and will stay lit for 10 seconds. At greater than 50% the LED glows Green, at less than 50% the LED glows Amber, and less than 25% the LED glows red and indicates the battery requires charging. If the less than 25% LED glows red, do not operate the lift. Remove the battery and fully charge before use.

### Service Required LED –

The Service Required LED will illuminate when the battery pack has been removed/replaced 120 times - approximately once every 4 months. This indicates that required maintenance for the lift must be completed. Please see the maintenance section of the Lift Owner's Manual for the requirements. The Service Required LED can be reset by inserting a standard FAT-formatted USB mass storage device (not included) into the USB Port on the bottom of the controller. **When the service light is illuminated the lift must not be used until required maintenance is performed.**

### Emergency Stop Button –

In the event of an emergency, or if you need to stop lift movement immediately, pressing the Emergency Stop Button (red button on the control) will stop all lift movement. At the same time an audible alert will sound for 10 sec. then pause for 5 sec. and then the sequence will repeat until the button is reset by turning it in the direction of the arrows on the button (clockwise). The Emergency Alert LED will also flash Red when the button is pressed and will remain flashing until the button is reset.

The Emergency Alert (audible and LED) can be activated by pressing any two buttons on the hand control at the same time (provided with the lift). This will stop all lift movement and activate the audible alert and the Red LED will flash. Once both buttons are released, the lift will return to normal operation and the emergency audible alert will silence.

### USB Port –

The LiftOperator control contains a USB port that is used to download the performance log of the lift. Using any standard FAT file formatted USB memory stick (widely available through retail outlets) insert the stick into the slot on the bottom of the control on the far right hand side. Press any of the touchpad control arrows; all three of the Battery Level LED's will flash. During downloading the Green greater than 50% Battery Level LED will flash. If the unit has a problem downloading the performance log the Red less than 25% LED will flash. Remove the USB from the port and re-insert it. If the Red 25% LED flashes again, confirm that the USB you are using is FAT file formatted. The information from the USB can be downloaded to a PC for review and/or copied to a spread sheet. The performance log will retain approximately 7,600 events. Once the file is full it will remove the oldest event and replace with the newest.

After the summary data, the events are shown with the oldest first. The first column is the time in seconds from that last event. The second column is the text describing the event. The third column is duration of the activity noted in seconds.

An example of a short log file:

<u>Activity</u>	<u>Description</u>
dev_id_upper,0	Programing data
dev_id_lower,1	Programing data
fw_rev,90	Firmware rev.
batt_volt_float,24929	Non-loaded battery voltage in millivolts
batt_volt_load,21487	Loaded battery voltage in millivolts
batt_capacity,99	Estimated battery capacity in %
charge_starts,8	Number of times charging was attempted



charge_completes,1	Number of times charging was finished successfully
0,power_on,1	Connecting Battery Pack
2,alert_pressed,	Emergency Button pressed
3,alert_released,	Emergency Button released
8,lift_up,2	Lift movement - up
5,lift_down,2	Lift movement - down
11,lift_up,2	
4,turn_left,2	Lift movement - turn left
3,turn_right,1	Lift movement - turn right
3,log_write,	USB File Download

**Battery Pack** - The battery pack is located on top of the Control Box and is removable.

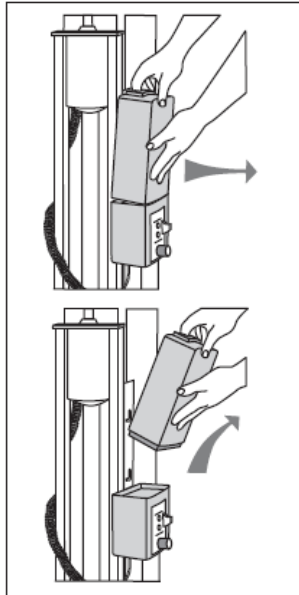

**To remove** - pull the battery pack away from the mounting plate so that the latch on the battery pack clears the side tabs on the mounting plate - then lift the battery pack up and away from the Control Box.

**To replace** - align the battery pack with the mounting plate so that the latch will drop over the center tab and that the bottom of the battery pack will fit in the recessed area on top of the Control Box. Lower the battery pack in place so that the latch is fully captured by the mounting plate and the battery pack drops fully seated onto the Control Box.

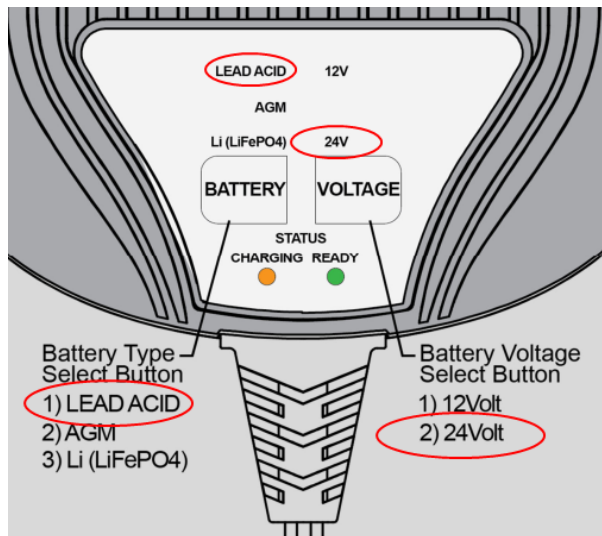

\*Image courtesy of Deltran Battery Tender

The battery pack should be charged daily. Do not allow battery to fully discharge, as it will shorten battery life. Whenever battery is removed from Control Box or lift that is not in use it is important to connect the battery to the charger. This ensures battery is fully charged and ready for use.

**Prior to connecting the charger to the battery, make sure that the LEAD ACID battery type is selected and that the selected voltage is 24V. After the correct battery type and voltage is selected, connect the charger to the battery.**

The battery charger has an LED indicator to show charging status. The following describes LED indicator operation.

**Amber Light Flashing** – The amber light flashing indicates that the battery charger has AC power and the microprocessor is functioning properly. If the amber light continues to flash, either the battery voltage is too low (battery pack needs to be replaced), or the battery charger is not properly connected to the battery.

**Alternating Green/Amber (Amber LED & Green)**

- This indicates reverse polarity connection to the battery.
- or
- The charger's safety timer has activated due to the battery not reaching its optimal voltage. The battery may be defective, contact S.R. Smith customer service for troubleshooting.

**Amber Light on Steady** – Whenever the amber light is on steady, a battery is connected properly to the charger and the charger is charging the battery. The amber light will remain on until the charger completes the charging stage.

**Green Light Flashing** – When the charger shows a green flashing light, the battery is 80% charged. Whenever possible, leave the battery on the charger until the green light is solid.

**Green Light on Steady** - When the green light stops flashing and remains on steady, the battery is fully charged and can be returned to service. The battery can and should be left on the charger when not in use.

Batteries have a normal lifespan of between 2-3 years, depending on use and care. A fully charged battery will provide approximately 30 to 40-lifting cycles, depending on the weight of the users. Prior to use the battery charge level should be checked by observing the LED indicator on the charger plug to ensure sufficient charge level. See warranty policy regarding battery replacement.

It is not necessary to fully discharge the battery prior to charging. Battery should be charged daily and cannot be overcharged. It takes up to twelve hours to fully charge depending upon battery usage. Do not allow battery to fully discharge, as it will shorten battery life. Whenever battery is removed from Control Box or the lift is not in use it is important to connect battery to charger. This ensures battery is fully charged and ready for use.

Do not drop the battery, as it could cause the unit to fail. If the battery case is cracked do not use and replace the battery. Do not place battery on a conductive surface. During temperature extremes beyond the range of 41 F (5 C) to 104 F (40 C) remove battery and place in a controlled environment or battery life may be shortened.

**Battery Disposal** - The batteries located inside the battery pack are recyclable and shall be disposed of in accordance with applicable local, state/provincial or federal/national regulations.

**Locking Plate Assembly** - The battery pack can be secured to the mounting plate using the provided lock plate assembly. To install open the lock plate so that the bottom tabs are moved close to one another to allow the lock plate to be inserted into the slots on the mounting plate secured to the lift. Close the lock plate assembly so that the tabs are captured by the slots. Insert a padlock (not provided) through the holes on the lock plate assembly to secure it.

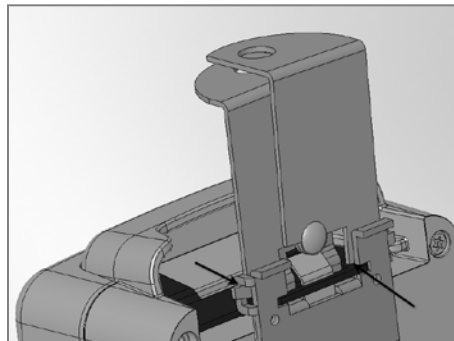
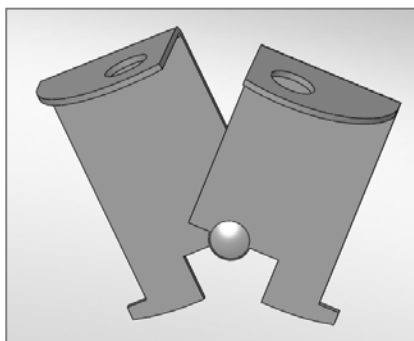

**Hand Control** - The four button unit controls all lift movements. The arrows indicate direction of movement. Control is fully waterproof and meets IP67 standards.

**Mast** - This vertical piece is bolted to the base assembly.

**Actuator** - Attached to mast, this part powers the up and down movements of the lift.

**Rotation Motor Assembly** - Consists of mounting plate, 24-volt motor and small gear.

**Hub Assembly** - Consists of hub, bearings, shaft, large gear and mast mounting plate.

**Horizontal Support Arms** - These two support arms connect the mast to the seat support arm. The longer horizontal support arm (actuator arm) connects to the actuator and initiates the lifting movements.

**Seat Support Arm** - Connects seat to the horizontal support arms.

**Seating System** - The seat is manufactured from roto-molded plastic with a stainless steel frame.

The seat belt must be used during each use. The footrest is removable and will float upwards to prevent damage if the seat is lowered too far. It is recommended that the seat be rinsed off with fresh water between each use and cleansed daily with a disinfectant solution of 1:100 dilution of household bleach to fresh water and then rinsed with fresh water. In the event of a contamination incident such as patient/user



excreta - cleanse seat and seatbelt immediately with the above disinfectant solution. Do not use seat or seatbelt if it is damaged or becomes worn out.

Armrests are included as a standard item on all S.R. Smith lifts. The armrests are designed so they can be rotated up out of the way during transfer.

This lift seat assembly is designed to be used exclusively with S.R. Smith aquatic access lifts.

## UNPACKING & ASSEMBLY INSTRUCTIONS

REFER TO THE DIAGRAM (page 21) FOR PARTS IDENTIFICATION.

### READ THESE INSTRUCTIONS IN THEIR ENTIRETY BEFORE UNCRATING THE SPLASH!

**Prior to opening the pallet, inspect the external condition for any visible damage. It is important that any damage be noted on the Bill of Lading. Immediately notify S.R. Smith or your Authorized Reseller of missing or damaged parts.**

**Ensure mounting anchor has been installed in the correct location in the pool deck for proper lift operation. It is recommended that the anchor be installed by a person familiar with installing pool deck equipment.**

**The Splash!** is shipped on a covered pallet and is VERY HEAVY. You will need the following tools for unpacking and assembly:

- 3/4" or 19mm socket wrench
- 9/16" or 14mm socket and 9/16" or 14mm wrench
- small flat blade screwdriver
- knife or cutters to cut shrink-wrap/bands

### Unpacking & Assembly Procedure for the Splash!

1. Cut open enclosure bag around the pallet - carefully remove plastic.
2. Cut bands around components.
3. Remove the accessory box and seat assembly. DO NOT remove housing cover. It is attached to the base.
4. Lift the base unit and insert it into the deck anchor using the metal handle located on the top of the Housing. DO NOT LIFT BASE UNIT USING PLASTIC HOUSING. Make sure that the tab located on the side of the Splash! base is aligned with the threaded tab in the LiftLock2 deck anchor. Use the 3/8" hex bolt, lock washer, and flat washer to secure the Splash! base to the LiftLock2 anchor. If you are installing the lift in a pre-existing anchor that does not include a threaded tab, contact S.R. Smith for information on a retrofit kit. Once the lift base has been placed into the deck anchor, unfasten the nuts and remove and discard the metal handle.

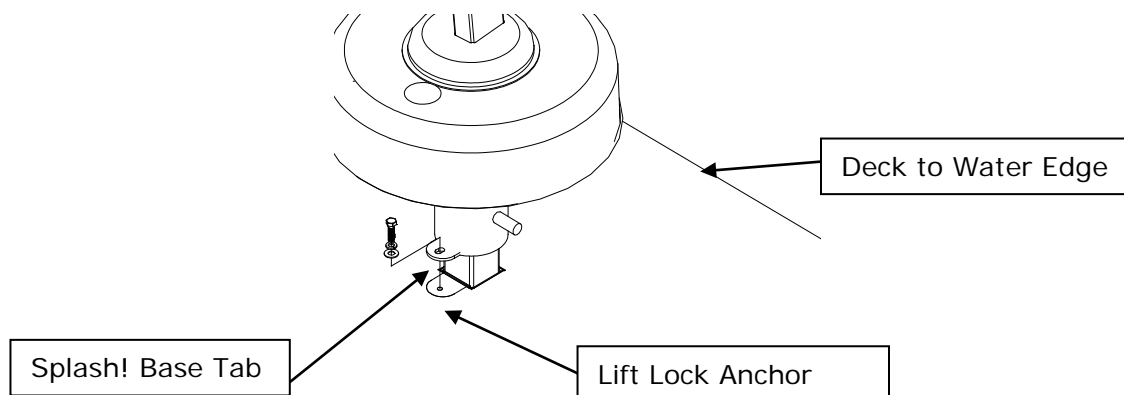

5. Position the mast assembly onto the housing cover by lowering the mast base onto the studs protruding from the housing. Attach the washers and lock nuts onto the studs and fully tighten using a 3/4" or 19mm socket wrench. Slide attachment cover to cover the bolts.

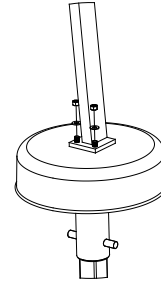

6. Remove plastic from mast assembly. Remove 3/8" (10mm) bolt and nut from actuator arm end. Following the illustration - attach actuator end to end of actuator arm using the same 3/8" (10mm) bolt and nut. Fully tighten bolt and nut using 9/16" (14mm) socket and wrench.

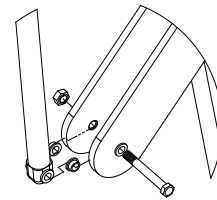

7. Remove twist tie and uncoil cable on top of housing. Insert plug (with red stripe) into connector #1 on Control Box. Insert cable into wire chase on front of mast, then push to close/lock wire chase. Make sure plug is secure.
8. Remove twist-tie and uncoil actuator cable at bottom of mast.
9. Insert actuator cable plug (green stripe with the "o" ring) into connector #2 on the Control Box. Make sure plug is secure.
10. Remove and unwrap hand control from accessory carton. Insert plug into large connector on the Control Box and hang hand control on handle. Make sure plug is secure.
11. Attach battery to Control Box. To remove battery pull slightly away from mounting plate and lift battery pack off of the Control Box.
12. Cover Control Box and battery with Console/Battery Cover to protect from moisture.
13. Check up and down controls for proper operation - both touch pad and hand controls.
14. Check side to side controls for proper operation – both touch pad and hand controls.
15. Check Emergency Stop button for operation/activation of internal sounder.
16. Attach seat assembly with bolt and thumbnut in appropriate hole. For storage, seat can be attached facing inward for less space.

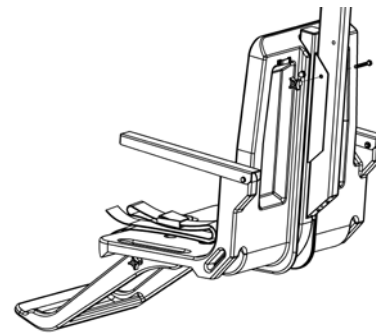

17. Attach foot rest to seat with bolts and thumbnuts.



### **POOL DECK INSTALLATION FOR THE SPLASH! LOCKING ANCHOR**

**Ensure Locking Anchor has been installed in the correct location in the pool deck for proper lift operation. It is recommended that the anchor be installed by a person familiar with installing pool deck equipment.**

The optimal mounting distance for the deck anchor is between 12"/30.5 cm to 18"/46cm from the edge of the pool. Please call S.R.Smith with any questions concerning deck anchor placement or if the SPLASH will work in your installation.

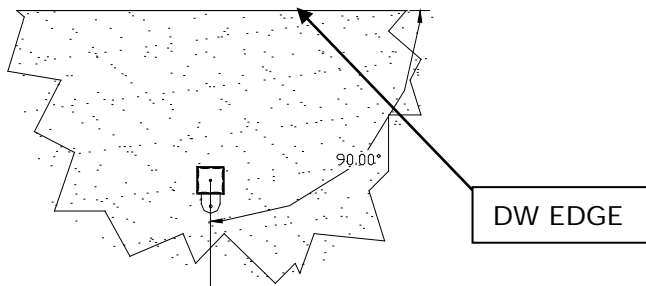

#### **Locking Deck Anchor**

(Install the anchor so the locking tab is perpendicular and furthest away from the Deck to Water (DW) edge), see Appendices A and B for details.

### **INSTALLING AN ANCHOR IN A CONCRETE DECK**

The proper installation of the anchor depends on the construction and condition of the deck. If the deck meets the thickness and re-enforcing requirements shown in Appendix A then the anchor can be installed according to the instructions outlined in Appendix A.

If the existing deck does not meet the requirements outlined in Appendix A then the anchor can be installed per the instructions in Appendix B, or you can consult with an engineering professional.

The deck anchor reaction loads can be found in the Specification Section of this manual.

Properly bond the anchor socket using the attached bonding screw per local codes.

## **USING THE Splash! LIFT**

**Obey all User Instructions listed in the Owner's Manual whenever using lift. Obey all Caution, Warning, Operating Instruction(s) and Labels located on the lift whenever using. It is the responsibility of the lift Owner to ensure that the correct safety procedures have been put in place and a risk assessment carried out. If a User is mentally challenged or has severe physical disabilities these issues must be taken into account to determine the number of persons required to complete the transfer onto the seat and the number of persons required to be in the water, ready to receive the User. If the Splash! will be used by a disabled person living on their own, a communication device should be installed in the area of use to call for assistance in the event of an emergency. Only persons healthy enough for water activities should use the Splash!. Users should consult with their physician to determine if water activities are appropriate for the User. Keep fingers and hands clear of lift arms during use.**

## Splash! Transferring Diagram

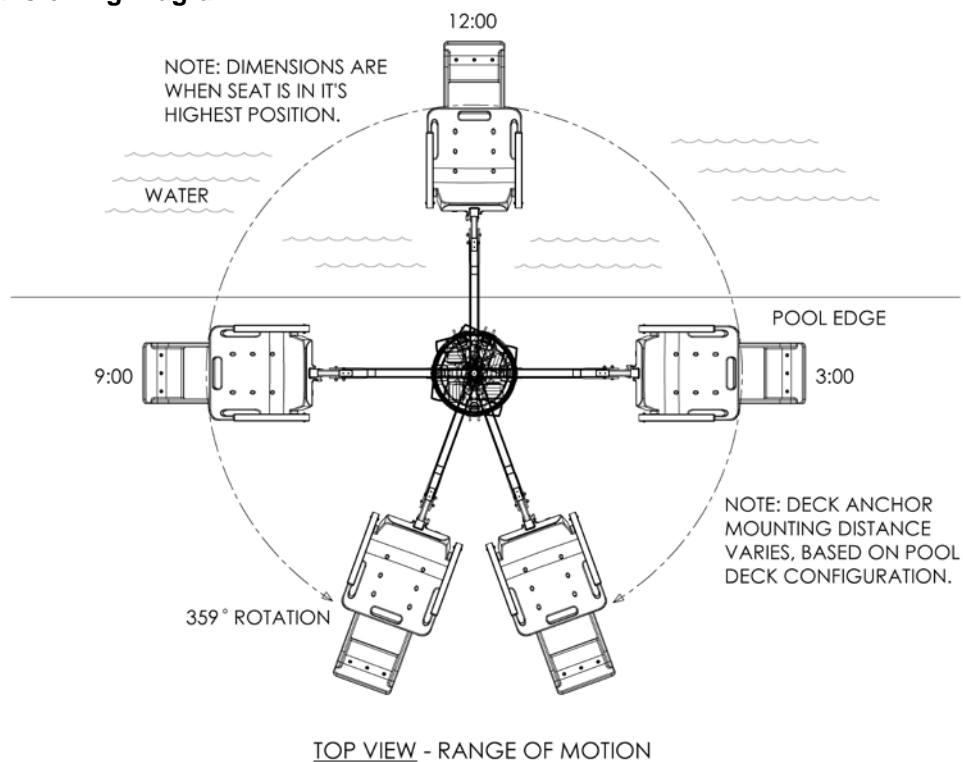

## TRANSFERRING

Once the unit is positioned for use, use the following procedure to transfer to the seat and into the water. Only persons healthy enough for water activities should use the Splash!. Users should consult with their physician to determine if water activities are appropriate for the User:

- Keep fingers and hands clear of lift arms during use.
- Rotate the seat to either side of lift for best transfer position.
- Raise or lower the seat to proper transfer height.
- Transfer onto the seat, ensuring that the user's weight is centered on seat. Armrests can be rotated up if necessary. If user has a wheelchair, keep the wheelchair close by for easy retrieval.
- Fasten Seat Belt - thread loose end of belt strap through buckle - pull tight - to close - press latch down on belt material.
- Raise seat to allow enough leg room for rotation.
- Rotate seat to the 12:00 position, over the water.
- Lower the seat into the pool. The waterproof hand control can remain connected to seat if swimmer is operating lift.
- Unfasten Seat Belt - grasp latch and lift up, pull loose end from latch.
- When finished, return to the seat, ensuring user's weight is centered on seat.
- Fasten Seat Belt.
- Raise seat to allow enough leg room for rotation.
- Rotate seat to original transfer position.
- Raise or lower seat to proper transfer height.
- Unfasten Seat Belt.
- Transfer off of the seat.

## IN CASE OF HAND CONTROL FAILURE



**Lifting failure** - In the event of a lifting failure, there are control buttons built into the control box. Press the appropriate up or down/left or right button located on the front panel of the control box.

**If the Splash! will be used by a disabled person living on their own, a communication device should be installed in the area of use to call for assistance in the event of an emergency.**

**If the Splash! will be used by a disabled person living on their own, a communication device should be installed in the area of use to call for assistance in the event of an emergency.**

### **STANDARD ACCESSORIES/OPTIONAL ACCESSORIES**

The following items are included with all pool lift models:

- Seat Belt Assembly - Nylon water-resistant belt for added security.
- Battery/Charger – 24-volt rechargeable battery.

Optional accessories may be purchased for your Splash! lift through your Authorized Reseller. The following accessories are available:

**Console/Battery Cover – P/N 910-1000:** Protects battery and control unit from exposure to moisture

**Total Cover - P/N 920-5000:** Made of weather resistant nylon material to keep unit protected from elements when not in use.

**Spine Board Attachment - P/N 500-1000:** Can be used to convert lift for use with any standard spine board. (Spine Board not included)

**Splash! Caddy - P/N 400-0000** - Facilitates handling, transporting and storing the Splash! Simplifies both insertion and removal from deck anchor and can be used as a storage rack when lift is not in use.

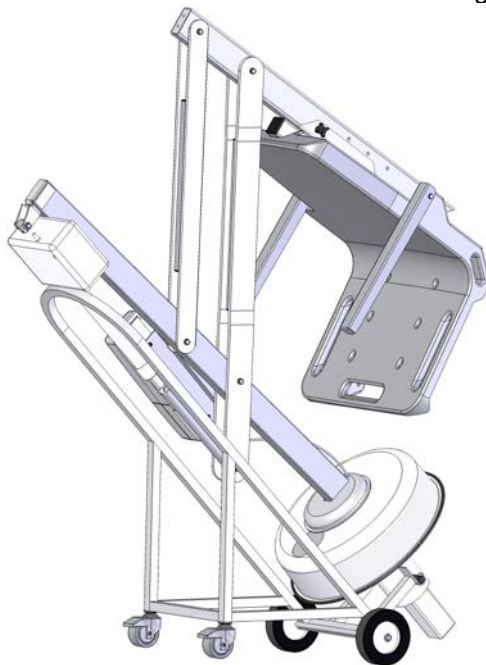

**Anchor & Cap – P/N 300-6600L** – Lift Lock deck anchor measures 3.125” / 79.3 mm OD, 2.75” / 6.98 cm ID. Includes cap and bonding screw.

**Console/Battery Cover – P/N 910-1000** – Protects battery and control unit from exposure to moisture.

## MAINTENANCE and CLEANSING

Minimal maintenance will prolong the life of your lift. Keep all electronic components clean and dry. Keep the Console/Battery Cover installed at all times to prevent moisture from collecting on the Control Box and battery. Excessive moisture collection can affect battery and lift performance and could lead to battery failure and/or the lift failing to operate. If the lift is used outdoors, an optional full cover is available and recommended.

Owners of lifts should be aware of any applicable local, state/provincial or federal/national regulations regarding the inspection and or testing of lifts.

**The following schedule shall be performed to insure proper operation with the Daily items performed before each use:**

Maintenance Performed	Daily	Weekly	Monthly
Check battery level before each use / Charge battery daily	✓		
Wipe Control Box and battery connection with a clean dry rag	✓		
Examine lift for any damage, loose or missing hardware	✓		
Test for normal operation	✓		
Spray gear assembly with a heavy-duty rust inhibitor/lubricant such as LPS 3 - Heavy-Duty Inhibitor		✓	
Make sure all cable connections are properly secured			✓
Inspect lift frame, mast, support arm and seat assembly for rust			✓
<b>Cleansing Performed – after each use</b>			
Rinse seat and seatbelt with fresh water between each use - Cleanse seat and seatbelt with a disinfectant solution of 1:100 dilution of household bleach to fresh water and then rinse with fresh water and dry entire lift daily. In the event of a contamination incident such patient/user excreta - cleanse seat and seatbelt immediately with the disinfectant solution*	✓		
Cleanse all battery connections with a nylon scouring pad			✓
Cleanse all metallic surfaces with a cleaner wax to maintain the finish of the lift			✓

**\* When using the disinfection solution avoid direct contact with the skin and eyes. In the event of a contamination incident - immerse the seat belt in the disinfection solution for 10 min. and then rinse thoroughly with fresh water.**

## TROUBLE SHOOTING

Be sure the battery is fully charged before troubleshooting.

Lift does not rotate

*Does lift raise or lower?*

Yes.

1. Check connection to Control Box. Be sure plug is pushed in all the way.
2. Check hand control connection to Control Box for damaged pins.
3. Check connections on terminal block located on frame for loose wires.
4. Check connection cable for damage.
5. Try operating the lift using the control buttons on the front panel of the controller. If the lift rotates when using the buttons on the control box, the hand control is likely the problem.
6. If the lift does not rotate when using the buttons on the control box, reverse the motor cables as follows: Locate the area on the Control Box where the cables are attached. Swap the actuator cable from connector #2 with the 24v motor cable from connector #1. Activate the up and down buttons on the hand control. If lift rotates, the problem is likely the hand control. If lift does not rotate, the problem is likely the 24v motor.
7. Contact your Authorized Reseller or S.R. Smith for replacement information.

*Does lift raise or lower?*

No.

1. Check battery charge level.
2. Check battery connection.
3. Use another fully charged battery. If lift continues to not function, replace the Control Box.

Lift does not Raise or Lower

*Does lift rotate?*

Yes.

1. Check connection to Control Box. Be sure plug is pushed in all the way.
2. Check hand control connection to Control Box for damaged pins.
3. Check connection cable for damage.
4. Activate the up and down buttons on the front panel of the control box. If lift raises and lowers, the problem is likely the hand control.
5. If the lift does not raise and lower when using the buttons on the control box, reverse the cables as follows: Locate the area on the Control Box where the cables are attached. Swap the actuator cable from the connector #2 and the 24v motor cable from connector #1. Activate the left and right buttons on the hand control. If the lift raises and lowers, the problem is likely the hand control. If the lift does not raise and lower, the problem is likely the Actuator.
6. Contact your Authorized Reseller or S.R. Smith for component replacement information.

*Does lift rotate?*

No.

1. Check battery charge level.
2. Check battery connection.
3. Use another fully charged battery. If lift does not function, replace the Control Box.

## LONG-TERM STORAGE

When storing the lift for an extended period of time:

- Wash seat with disinfectant solution and then rinse with fresh water and dry entire lift
- Spray gear assembly with a heavy duty rust inhibitor and lubricant such as LPS 3 - Heavy-Duty Inhibitor
- Keep the battery on the charger in a dry temperature controlled area
- Cover unit and store in a dry location away from pool chemicals

*Questions/Comments - Contact us at 800.824.4387 or 503-266-2231 or [customercare@srsmith.com](mailto:customercare@srsmith.com). For information regarding Authorized Resellers worldwide visit [www.srsmith.com](http://www.srsmith.com)*

## WARRANTY INFORMATION

**The S.R. Smith warranty becomes effective on the date of manufacture.**

To initiate a warranty replacement, Please follow the process outlined below.

1. **Take photos of the damaged product.**
  - a) The photo must include the entire unit
  - b) Also include one photo or more of the damaged area.
2. **Write down or take a photo of the serial # sticker from the product.**

S.R. Smith provides a serial # for every pool lift we produce. The sticker with the serial number can be found at the bottom of the mast near the base.
3. **Attach the photos and the serial # to a written request for replacement under the S.R. Smith warranty.** Please include the following information:
  - a) Product name and description.
  - b) Date of purchase and/or date of installation.
  - c) Description of damage.
  - d) Shipping address with a contact name and phone number.
4. **Send photos, serial # sticker and your written request by email or mail to [customercare@srsmith.com](mailto:customercare@srsmith.com) or:**

S.R. Smith, LLC  
PO Box 400  
1017 SW Berg Pkwy  
Canby, OR 97013  
Attn: Warranty Specialist

**\*\*NOTE:** Missing information will result in a processing delay and possibly denial of your claim.

Should you have any questions regarding this process, please contact S.R. Smith's Warranty specialist at 800.824.4387 or 503.266.2231 or email [customercare@srsmith.com](mailto:customercare@srsmith.com)

## SPECIFICATIONS

### Splash! 300

#### 1. Dimensions/Capacity

Overall Height	66.25"/168cm
Base Dimensions	19.25"/49cm Dia.
Total Weight	160 lb/72.5 kg
Overall Length (footprint)	90"/229cm (fully extended, with footrest) 68.75"/176cm (fully retracted, with footrest) 40"/102cm (in stored position, no footrest)
Power	24V DC
Battery Life	30 cycles (approx.)
Lifting Capacity	400 lb/181 kg - 300 lb/136 kg (Splash! Extended Reach)
Anchor Reaction Load	
Vertical	430 lb/195 kg
Torque	1280 ft lb/1735 NM
Seat Width	23"/58.5cm

#### 2. Actuator

Lifting	Screw Type Mechanical Actuator
Max. Thrust	1680 lb/7472N
Voltage	24V DC
Max. Amp	9
Max. Speed	0.59 inch/sec./1.49cm/sec.

#### 3. Motor

Rotation	24 VDC, 13 RPM
Gearing Ratio	9:1

#### 4. Battery

Power	24 VDC, IP65 Gel Lead Acid
Temperature Range	41 F (5 C) to 104 F (40 C)

#### 5. Range of Motion

Lifting	Variable to configure to each pool. 44"- 58"/112cm – 147cm total travel from highest to lowest point w/standard actuator.
Seat Depth	18-20"/46cm – 51cm below water line.
Rotation	359°

#### 6. Noise

Noise level below 50 dB (A), measured according to DS/EN ISO 3746"

#### 7. Materials and Finish

Frame	Powder Coated Stainless Steel
Housing	Vacuum Formed ABS Plastic
Arms	Powder Coated Aluminum
Mast	Powder Coated Stainless Steel
Seat Assembly	Seat: Roto-Molded Plastic Frame: Powder Coated Stainless Steel
Covers	Urethane coated nylon

## PARTS LIST (SPLASH! 300)

Item #	Part #	Description
1	100-5000A	LA34 Actuator
2	1001499-BC	4 Button Control Unit
4	1001495-BC	Battery Pack
5	1001530-BC	Battery Charger (not shown)
6	100-4000A	Hand Control
7	120-1100	24v Motor
8	135-1000	Hub Assembly
9	120-1000	Motor Mount Assembly
10	800-5065	Small Gear
11	150-1100A	Mast Assembly
12	150-1200A	Actuator Arm Assembly
13	150-1300A	Support Arm Assembly
14	150-1400A	Seat Arm
15	160-8000A	Seat Assembly
16	160-2300A	Foot Rest
17	300-1100	Splash! Base Assembly
18	300-5200A	Mast Collar
19	300-5000A	Splash! Housing
20	900-1000	Seat Belt
21	910-1000	Console Cover (not shown)
22	940-1100	Splash! Mast Cover (not shown)
23	970-5000	Seat Cover (optional accessory, not shown)
24	900-6000	Stability Strap (optional accessory, not shown)

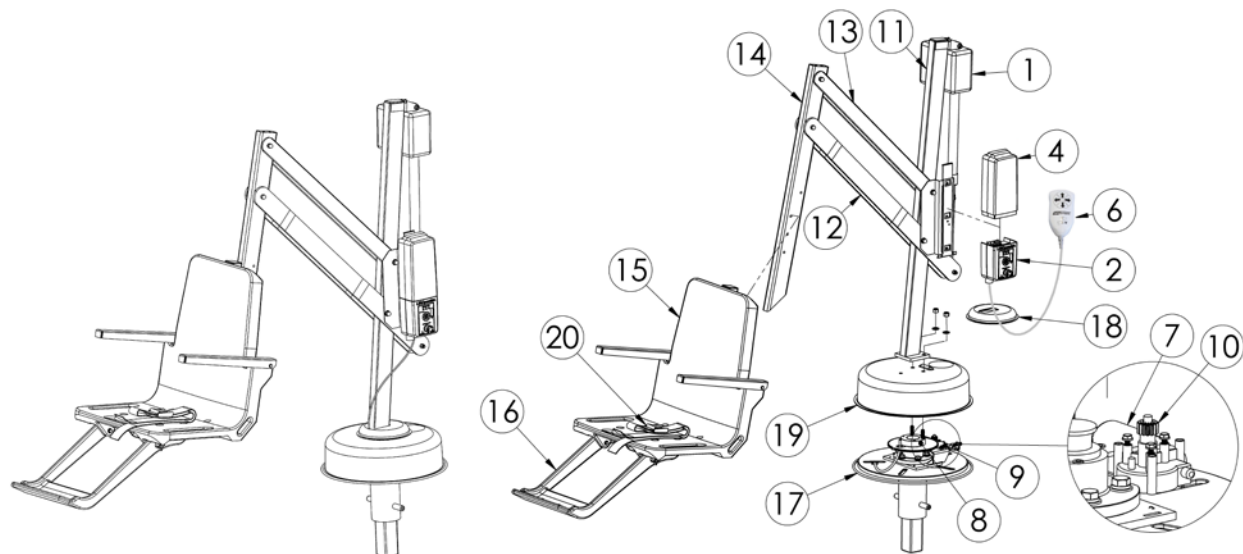

## PARTS LIST (SPLASH! Hi/Lo or SPA)

Item #	Part #	Description
1	100-5000A	LA34 Actuator
2	1001499-BC	4 Button Control Unit
4	1001495-BC	Battery Pack
5	1001530-BC	Battery Charger (not shown)
6	100-4000A	Hand Control
7	120-1100	24v Motor
8	135-1000	Hub Assembly
9	120-1000	Motor Mount Assembly
10	800-5065	Small Gear
11	150-2100A	Splash! Hi/Lo Mast Assembly
12	150-2200A	Splash! Hi/Lo Actuator Arm Assembly
13	150-2300A	Splash! Hi/Lo Support Arm Assembly
14	150-2400A	Splash! Hi/Lo Seat Arm
15	160-9000A	Seat Assembly Hi/Lo
16	160-2300A	Foot Rest
17	300-1100	Splash! Base Assembly
18	300-5200A	Mast Collar
19	300-5000A	Splash! Hi/Lo Housing
20	900-1000	Seat Belt
21	910-1000	Console Cover (not shown)
22	940-1000	Splash! Mast Cover (not shown)
23	940-2000	Splash! Hi/Lo Mast Cover (not shown)
24	160-8000A*	Seat Assembly* (Not Shown)
25	970-5000	Seat Cover (optional accessory, not shown)
26	900-6000	Stability Strap (optional accessory, not shown)

\*For Spa model only

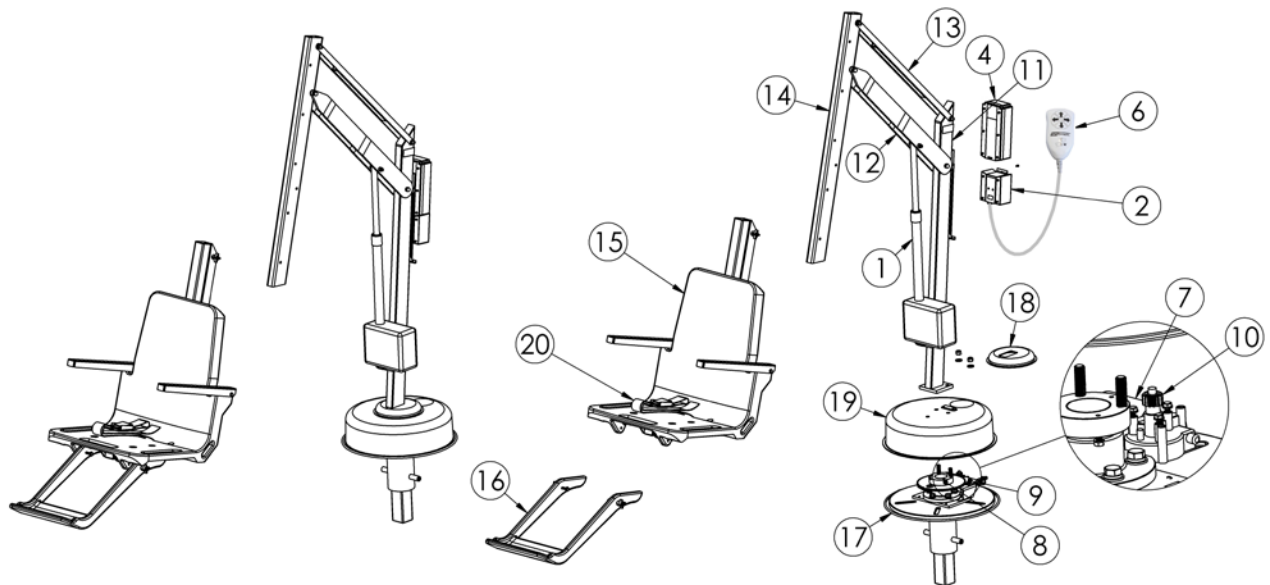

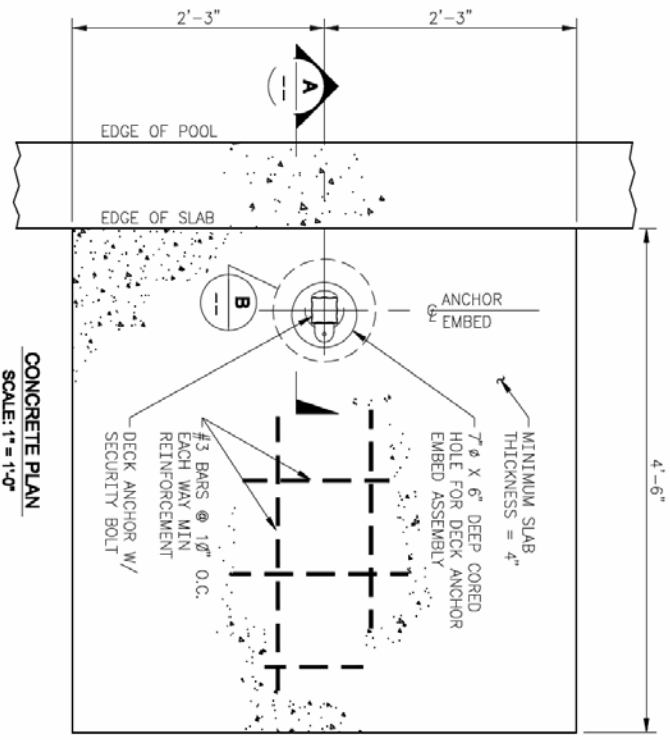

**CONCRETE PLAN**  
SCALE: 1" = 1'-0"

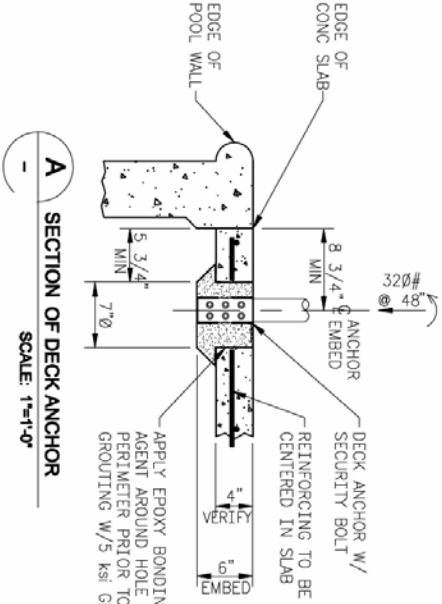

**A SECTION OF DECK ANCHOR**  
SCALE: 1" = 1'-0"

NOTE: VERIFY THE SLAB THICKNESS AFTER CORING. DO NOT INSTALL IF SLAB IS LESS THAN 4" THICK.

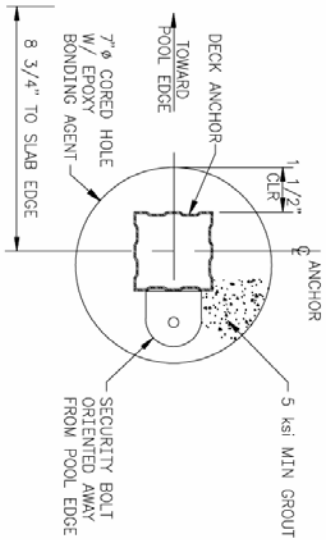

**B DETAIL OF DECK ANCHOR ORIENTATION**  
SCALE: 3" = 1'-0"

- GENERAL NOTES:**
1. NORMAL WEIGHT OF CONCRETE = 150 lbs/ft<sup>3</sup>.
  2. CONCRETE MINIMUM COMPRESSIVE STRENGTH AT 28 DAYS TO BE f'<sub>c</sub> = 2500 psi.
  3. REINFORCING BARS SHALL CONFORM TO ASTM A615, GRADE 60, DEFORMED.
  4. PRECISION NON-SHRINK CEMENT GROUT SHALL HAVE A MINIMUM COMPRESSIVE STRENGTH OF 5000 psi AT 28 DAYS. SUBMIT PRODUCT SPECIFICATIONS FOR APPROVAL.
  5. EPOXY BONDING AGENT TO BE FLEXIBOND 5400 OR APPROVED EQUAL.
  6. MAXIMUM LOAD = 320 lbs AT 48 INCHES.

	
P.O. BOX 400 CANBY, OREGON 97013 503-298-2231	
<b>SPLASH 300 LIFT CONG. ATTACHMENT TO 4" REINF. PAD</b> <b>PLAN, SECTION &amp; DETAIL</b>	
SCALE: AS NOTED	DWG. NO. D 0021-SR
DATE: 14MAR11	SHEET# 012



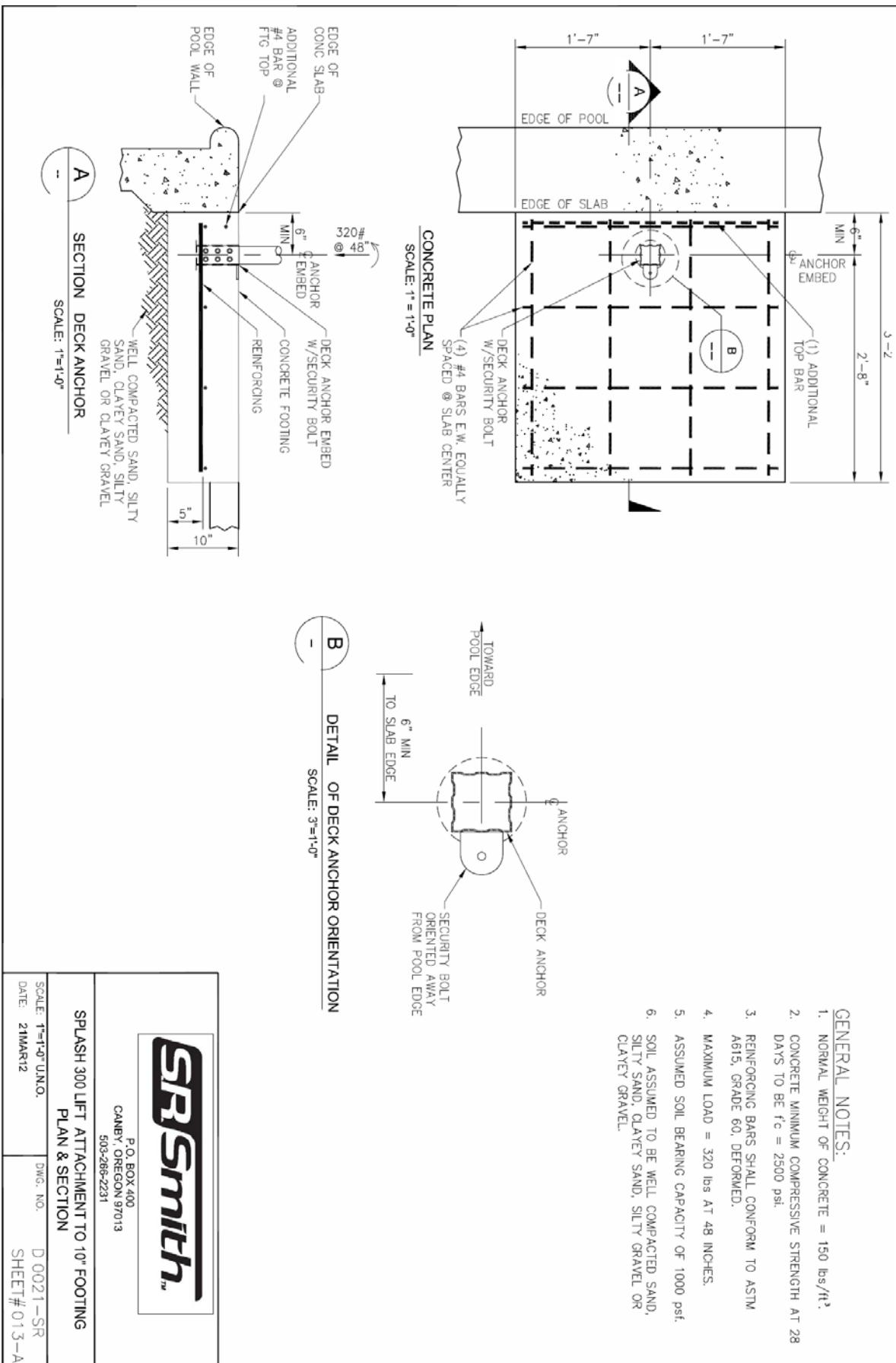

P.O. BOX 400  
CAMBY, OREGON 97013  
503-266-2231

**SPLASH 300 LIFT ATTACHMENT TO 10" FOOTING  
PLAN & SECTION**

SCALE: 1"=1'-0" UNO.	DWG. NO. D 0021-SR
DATE: 21MAR12	SHEET# 013-A