

# THE SWIM CLUB II™ FUNSLIDE™

## ASSEMBLY AND INSTALLATION INSTRUCTIONS



### **\* \* CAUTION \* \***

S.R. SMITH SWIM CLUB II™ FUNSLIDES™ ARE MANUFACTURED FOR INSTALLATION AND USE ON INGROUND POOLS ONLY. SWIM CLUB II™ FUNSLIDES™ ARE NEVER TO BE INSTALLED AND USED ON ABOVEGROUND POOLS, ONGROUND POOLS, HOUSEBOATS, BOAT DOCKS, FLOATING DOCKS OR PLATFORMS.

CORPORATE HEADQUARTERS  
WESTERN SALES AND MANUFACTURING PLANT  
P.O. Box 400 • 1017 SW Berg Parkway  
Canby, Oregon 97013  
(503) 266-2231 • (503) 266-4334  
[www.srsmith.com](http://www.srsmith.com)

## Table of Contents

<u>Topic</u>	<u>Page #</u>
Introduction.....	2
Applicable Standards and Codes.....	2
Assembly and Installation.....	2
Drawings.....	2
Parts List/ Anchor Kits.....	3
Left Curve Footprint.....	4
Right Curve Footprint.....	5
Left Curve Slide with Flush Deck Mounting.....	5
Assembly Instructions for In-Deck Mounting.....	6
Electrical Bonding.....	9
Manufacturer's Placement Instructions.....	10
Installed Slide's Structural & Installation Checklist.....	12

## INTRODUCTION

S.R. Smith Swim Club II™ FunSlides™ are manufactured for installation and use on inground swimming pools only. S.R. Smith Swim Club II™ FunSlides™ are NEVER to be installed and used on aboveground pools, onground pools, houseboats, boat docks, floating docks or platforms.

## APPLICABLE STANDARDS AND CODES

1. All S.R. Smith Swim Club II™ FunSlides™ are manufactured in accordance with Consumer Products Safety Commission STANDARD FOR SWIMMING POOL SLIDES, 16 CFR Ch. 11 Part 1207 (latest edition).
2. Installer must comply with all applicable governmental and building codes.

## ASSEMBLY AND INSTALLATION

All S.R. Smith Swim Club II™ FunSlides™ are inspected prior to shipment from the factory. Proper assembly and installation is mandatory. Improper assembly and installation voids S.R. Smith's warranty and may affect the safety of the user. S.R. Smith cannot and does not guarantee customer's concrete deck.

## DRAWINGS

All drawings in these Assembly and Installation Instructions (FIGURES A through L) are for illustration purposes only and are NOT TO SCALE.

## PARTS LIST

Ref # *	PART #	DESCRIPTION	QUANTITY
1	05-14-127	1/4" x 20 UNC x 1-1/4" Thread Cut Screw S/S	2 ea.
2	5-143	1/4" x 3/4" Flat Washer	2 ea.
3	05-622	5/16" x 3/4" Black Rubber Washer	2 ea.
4	05-31-110	5/16" x 1" Hex Washer Head Tek Screw	4 ea.
5	05-150	3/8" x 1-1/2" Flat Washer S/S	2 ea.
6	5-151	3/8" Lock Washer S/S	8 ea.
7	05-738	3/8" x 18 UNC x 3-1/2" Bolt S/S	8 ea.
8	05-762	1/2" Med S/S Clip	1 ea.
9	05-757	1/2" FIPT x 1/2" Hose Barb Elbow	1 ea.
10	05-758	1/2" MPT x 3/8" Hose Barb Tee	1 ea.
11	05-760	1/2" Plastic Hose Clamp	2 ea.
12	05-761	3/4" Plastic Hose Clamp	1 ea.
13	06-654	Swim Club II™ FunSlide™ Assembly & Installation Instructions	1 ea.
14	06-655	Swim Club II™ FunSlide™ Owner's Manual	1 ea.

## SLIDE WEDGE ANCHOR SOCKET KIT (OPTIONAL – For Removable Installation)

Ref # *	PART #	DESCRIPTION	QUANTITY
15	AS-100B	Bronze Anchor Socket	6 ea.
16	EP-100F	Round Escutcheon Plate	6 ea.

\* Ref #s are shown as (#\_\_ ) in these ASSEMBLY AND INSTALLATION INSTRUCTIONS

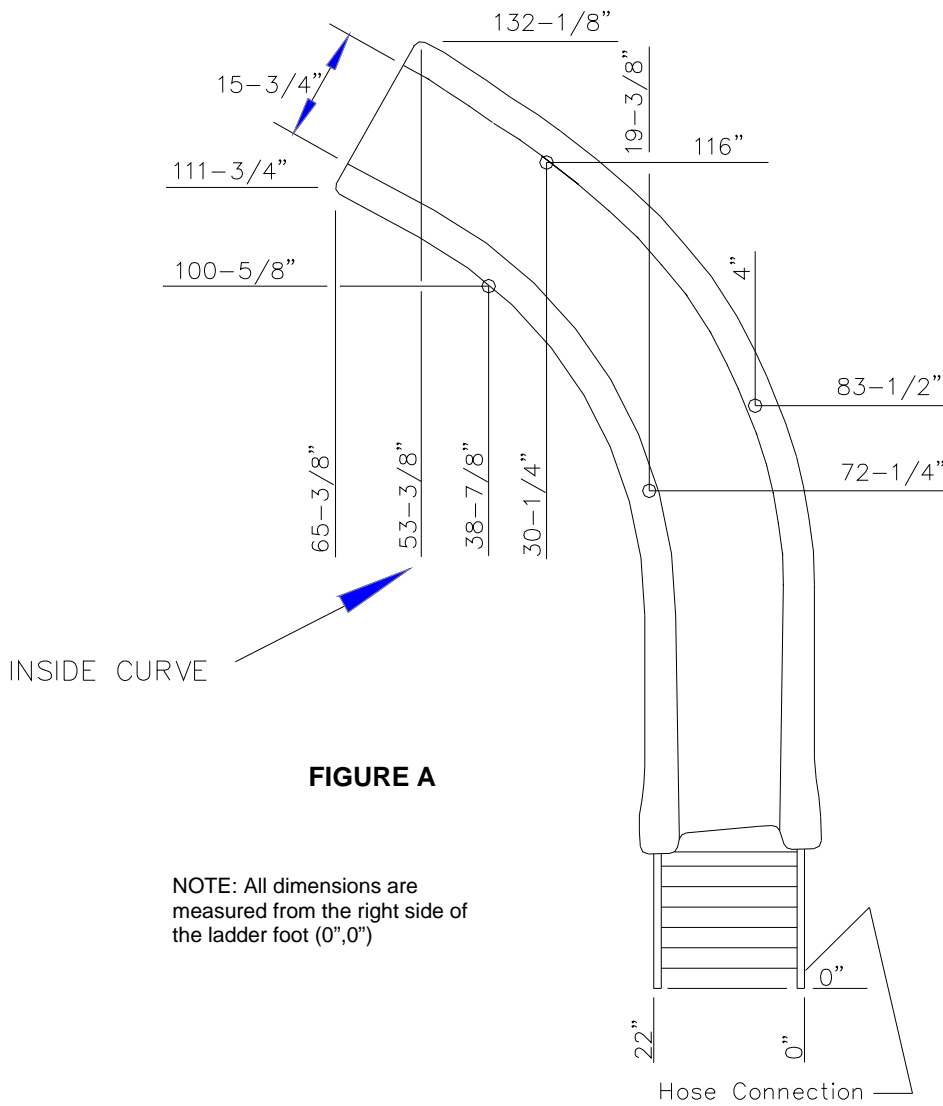

NOTE: All dimensions are measured from the right side of the ladder foot (0",0")

## **LEFT CURVE FOOTPRINT**

The purpose of this footprint is to serve as a GUIDELINE ONLY for approximate placement of the slide relative to the pool's edge. The actual dimensions after installation may vary according to the slope of the deck and the angle that the slide is oriented relative to the pool wall. **YOU MUST FOLLOW THE INSTALLATION INSTRUCTIONS AS PRINTED IN THIS MANUAL.**

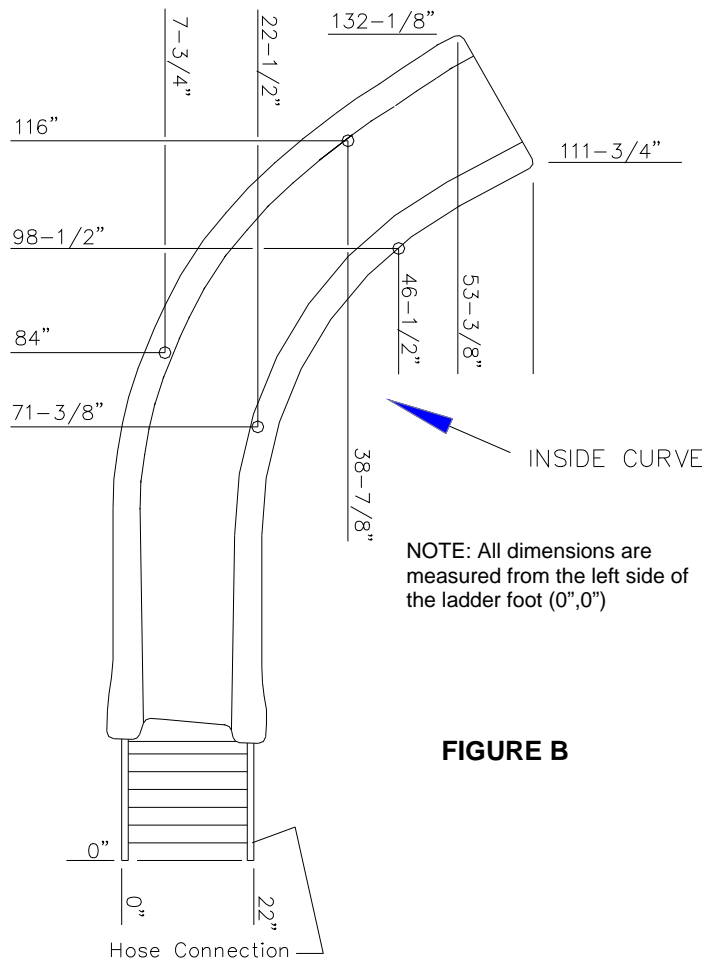

**FIGURE B**

## RIGHT CURVE FOOTPRINT

The purpose of this footprint is to serve as a GUIDELINE ONLY for approximate placement of the slide relative to the pool's edge.

The actual dimensions after installation may vary according to the slope of the deck and the angle that the slide is oriented relative to the pool wall.

**YOU MUST FOLLOW THE INSTALLATION INSTRUCTIONS AS PRINTED IN THIS MANUAL.**

## LEFT CURVE SLIDE WITH FLUSH DECK MOUNTING

The purpose of this side view is to serve as a GUIDELINE ONLY for approximate placement of the slide relative to the deck. The actual dimensions after installation may vary according to the slope of the deck and the angle that the slide is oriented relative to the pool wall. When installing the slide in the deck, these dimensions will be reduced by at least 4 inches.

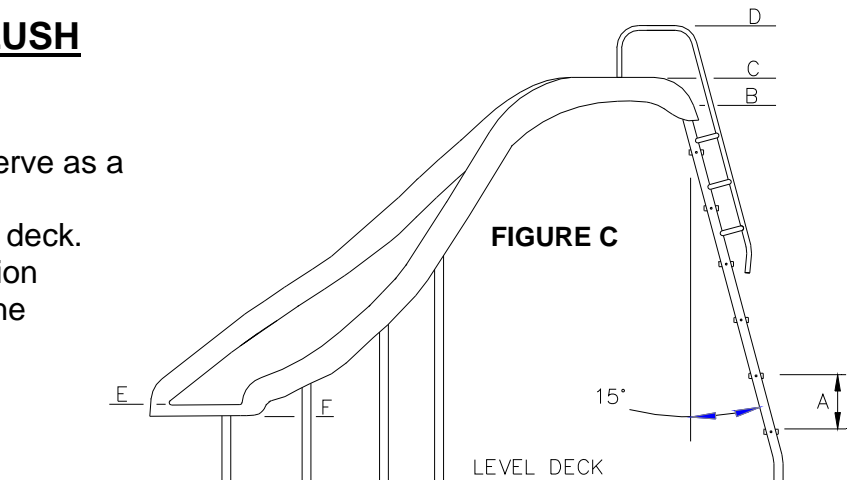

**FIGURE C**

### HEIGHT ABOVE DECK LEVEL OF:

- (A) Ladder step spacing:
- (B) Top runway surface:
- (C) Top runway side rail:
- (D) Top of handrail:
- (E) Exit runway surface:
- (F) Bottom of slide at exit end:

### LEFT CURVE

- 11"
- 78"
- 83-1/2"
- 95-1/2"
- 12-1/2"
- 10-3/4"

### RIGHT CURVE

- 11"
- 78-1/2"
- 84"
- 96"
- 13"
- 11"

## **ASSEMBLY INSTRUCTIONS FOR IN-DECK MOUNTING**

1. Place the slide runway upside down on a surface that will not scratch the slide.
2. Open the ladder and parts carton and locate the ladder and the 4 legs.
3. Insert the top of the slide ladder all the way into the two sockets at the top of the slide.
4. Insert two short legs in the leg sockets nearest the bottom of the slide with the longest short leg to the outside curve of the slide. Insert the longer legs in the remaining sockets with the longer leg to the outside curve. Do not attach the legs permanently at this point.
5. Carefully turn the slide with the legs and ladder upright for setup. It will be necessary for two people to perform this to avoid damage to the slide and the legs. If necessary use something such as tape to temporarily hold the legs in place while turning the slide over.
6. Place the slide at the desired location relative to the pool wall. See MANUFACTURER'S PLACEMENT INSTRUCTIONS on pages 10 & 11.
7. Ensure that the exit runway surface does not exceed 20 inches above the water surface, nor less than 8 inches above the deck/coping surface (see FIGURE I page 10). The exit runway surface is measured at the point of transition between the runway and the beginning of the exit end radius.
8. Ensure that the ladder is not twisted relative to the slide.
9. For a permanent installation insert 3/8" diameter rebar (not provided) into the holes located at the bottom of each leg making sure that the rebar will be a minimum of three inches (3") below the deck surface. For a removable installation wedge anchor sockets may be used. For this type of installation slide an (#16) escutcheon over each leg of the slide and ladder before placing into the (#15) Institutional Anchor Socket.
10. Install electrical bonding as local code specifies. (see ELECTRICAL BONDING page 9)
11. Secure the ladder so that the ladder steps are level, from side to side, and the ladder is slopped 15 degrees from vertical. (see FIGURE C page 5)
12. Adjust the top runway of the slide so that it is level, from side to side (position A) and lengthwise (position B) as shown in FIGURE D.

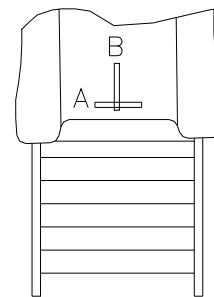

**FIGURE D**

13. Underneath the top portion of the slide, on the inside flat surface next to the ladder socket, use the existing holes as a template to drill a pilot hole using a #7 drill bit through each ladder post. (see FIGURE E below)

14. At the end of the braided tubing extending from the ladder post, insert the (#9) 1/2" Female Pipe Thread x 1/2" Hose Barb Elbow coupled with the (#10) 1/2" Pipe Thread x 3/8" Hose Barb Tee. Use teflon tape at connection to prevent leaking. Secure with a (#12) 3/4" Plastic Hose Clamp. Note: For a right curved slide this braided tubing will need to be trimmed to the proper length.

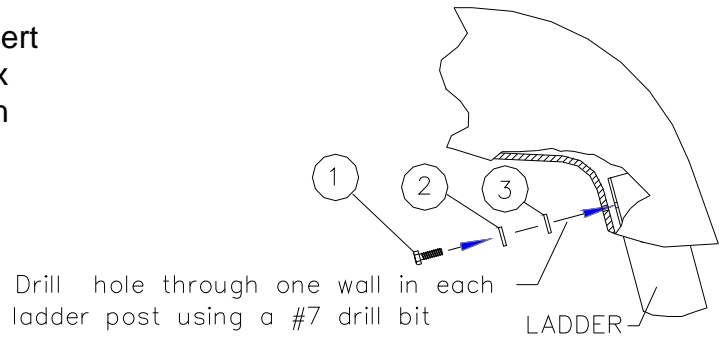

**FIGURE E**

15. To secure the ladder to the slide screw into the previously drilled holes (one per side post) a (#1) 1/4" x 1-1/4" Thread Cutting Screw, a (#2) 1/4" x 3/4" Flat Washer and a (#3) 5/16" x 3/4" Rubber Washer tightening to 8 ft.-lbs of torque. DO NOT OVER TIGHTEN. In addition to this, for the hole closest to the braided tubing, also use a (#8) 1/2" Med. S/S clip to secure the braided hose with the attached fittings in place.
16. Attach the 3/8" tubing from the slide to the tee and secure with the (#11) 1/2" Plastic Hose Clamps.

17. Level as close as possible the exit runway surface horizontally from side to side, approximately nine inches (9") up from the exit end, using a small level no longer than nine inches (9"). (see FIGURE F)

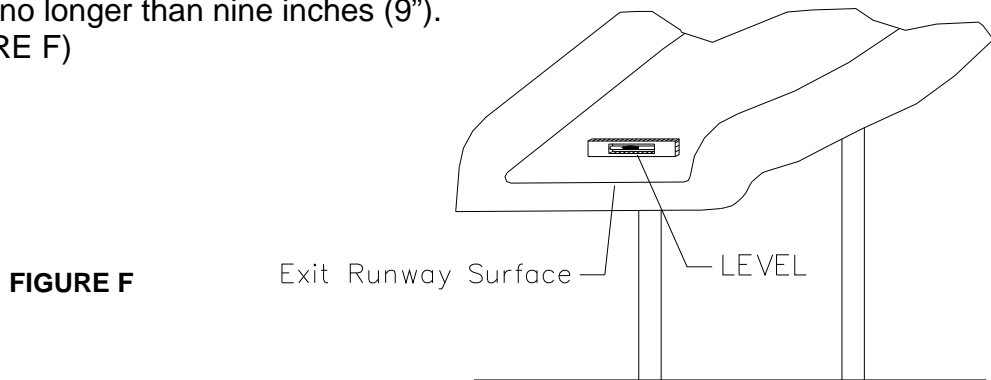

**FIGURE F**

18. If necessary the legs can be adjusted up and down within the leg sockets to help adjust for level. Once the slide is properly leveled the legs shall be permanently attached by drilling a 1/4" hole into each leg using the hole on the leg socket as a guide and fastening with the (#4) 5/16" Hex Head Washer Head Tek Screws.
19. Insert the two handrails into the holes on the top of the slide runway rails.
20. Secure each handrail to the ladder posts using a (#7) 3/8"-16UNC x 3-1/2" Bolt and a (#6) 3/8" Lock Washer. Tighten until Lock Washers are fully compressed.

21. Secure each handrail to the top of the slide by using a (#7) 3/8"-16UNC x 3-1/2" Bolt, a (#6) 3/8" Lock Washer and a (#5) 3/8" x 1-1/2" Flat Washer. (see FIGURE G)

22. Plumb the water supply to the slide ladder as desired. Install water supply line to base of ladder.

23. After connecting the water hose to ladder water connection, turn on water slowly, to check for leaks. Adjust water flow until spray nozzles provide a uniform water spray over the runway surface without any over spray.

24. Secure the slide, so that it will not move during the concrete pour, to ensure that the settings remain the same.

25. SUGGESTION: To ensure easy removal of concrete from legs and ladder, wax or wrap with wax paper approximately 12 inches above deck level.

26. Proceed with pouring the concrete deck and finish as desired. Let concrete cure 24 hours before using slide.

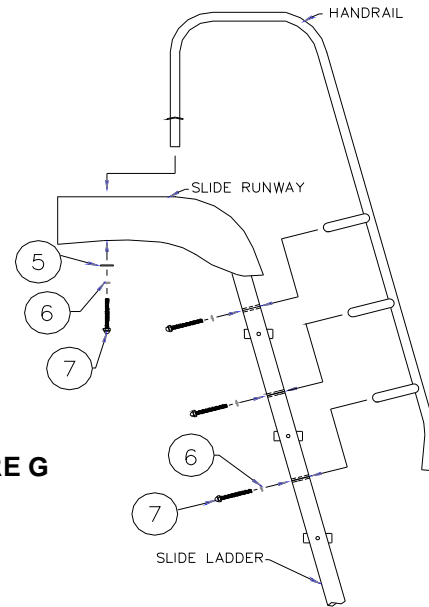

FIGURE G

## **ASSEMBLY INSTRUCTIONS FOR EXISTING CONCRETE DECKS**

1. Assemble the slide as outlined in the previous steps on pages 6 through 8.
2. With the slide in its proper position mark the location of each leg on the deck. This will serve as a template for drilling the holes necessary to cement the slide in place.
3. Drill the proper diameter holes in the deck for the type of mounting used such as wedge anchor sockets or mounted directly with rebar.
4. Place the slide in the holes, bonding as required. With the slide completely checked for assembly and leveled into the selected position, cement the legs in place with an epoxy or hydraulic cement making sure there are no void spaces.
5. Let cure 24 hours before using slide.

## ELECTRICAL BONDING

If electrical bonding is required by the local governmental regulations, it shall be done in accordance with Article No. 680 of the current National Electrical Code or the local Code whichever is greater.

## MANUFACTURER'S PLACEMENT INSTRUCTIONS

1. The critical dimensions for placement of the slide are as shown in FIGURES I and J.
  - A. The slide exit runway surface shall not exceed twenty inches (20") above the water surface and not less than eight inches (8") above the deck/coping surface. (see Figure I)
  - B. The slide shall be positioned so that all water flowing off the runway exit drops into the pool.
  - C. The minimum depth of water below the exit lip of the slide shall be three feet (3') and increases to four feet six inches (4'-6") at Pt.A which is a distance of four feet six inches (4'-6") from the exit lip of the slide. (see Figure I)
  - D. A minimum depth of four feet six inches (4'-6") shall be maintained at a distance of nine feet (9') along the extended centerline of the slide from Pt. A. (see FIGURE I)

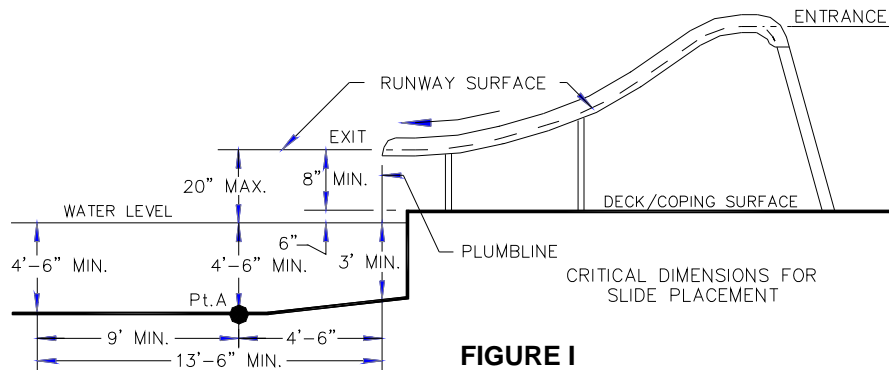

**FIGURE I**

1. A minimum clearance area in front of the slide shall be maintained away from the coping, another slide, a diving board or a rope and float line. (see FIGURE L)
  - A. The minimum clearance distance on either side of the extended centerline of the slide runway shall not be less than three feet six inches (3'-6") at a point no less than two feet six inches (2'-6") from the exit of the slide and extending a distance of thirteen feet six inches (13'-6") in front of the slide. (see FIGURE J)

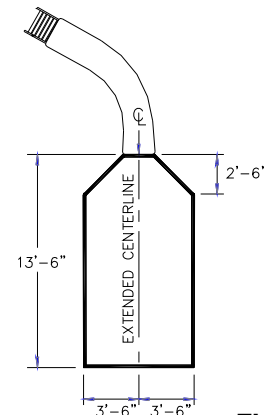

**FIGURE J**

SLIDE  
MINIMUM CLEARANCE AREA

- B. The minimum clearance area in front of a diving board is a minimum distance of three feet six inches (3'-6") on either side of the board's centerline. Pt.C extends a minimum distance of "C" from the tip end of the board. The width distance "W" on either side of Pt.C is given in CHART 1 and shown in FIGURE K.

### CHART 1

BOARD MINIMUM CLEARANCE AREA			
TYPE	"C" DIMENSION	"W" DIMENSION	
I	14'-6"	5'-0"	
II	14'-6"	6'-0"	
III	16'-6"	6'-0"	
IV	18'-6"	7'-6"	
V	21'-0"	7'-6"	
VI	18'-6"	9'-0"	
VII	21'-0"	10'-0"	
VIII	25'-0"	11'-0"	
IX	31'-6"	12'-0"	
Residential Pools are Types I-V . Public Pools are Types VI -IX			

See ANSI/NSPI-5 2003 STANDARD FOR RESIDENTIAL INGROUND SWIMMING POOLS Article 5.9 Drawings and Diagrams of Type I-V Diving Equipment Pools or ANSI/NSPI-1 1991 STANDARD FOR PUBLIC SWIMMING POOLS Article 4.6 Minimum Dimensions for Diving Portion of Class B and C Pools.

"C" DIMENSION FOR BOARD = AB + BC or L2 + L3

"W" DIMENSION FOR BOARD = WIDTH AT PT.C

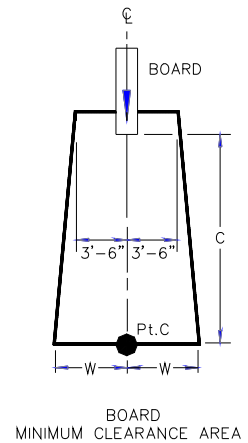
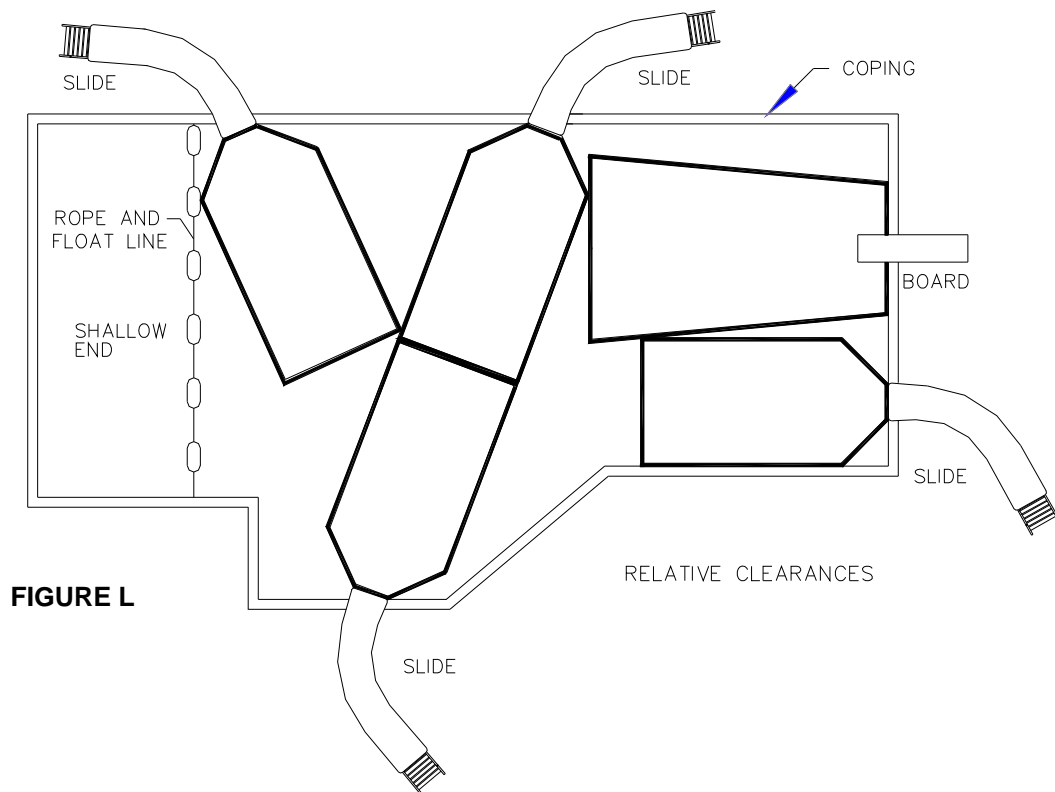

FIGURE K

- C. The minimum clearance area of a slide or diving board shall not intersect any coping or rope and float line. (see FIGURE L) The minimum clearance area of a slide or diving board may intersect each other provided that they are not used simultaneously.



## **INSTALLED SLIDES' STRUCTURAL & INSTALLATION CHECKLIST**

1. Inspect the runway for visible cracks or tears.
2. Inspect the slide for sharp edges, protrusions, cracks or tears.
3. Inspect all ladder tread or step-attachment points for evidence of shear, bending yield, or fatigue in the ladder steps, rails, or attachments means. Yield is evidenced by crystallization or fine cracking of the ladder tread and/or surface.
4. Inspect the ladder handrails for rigidity and attachment. (Can they be pulled out of their sockets?)
5. Measure the following dimensions and compare with the Manufacturer's Placement Instructions on pages 10 and 11. Depending on installation also review the ANSI/NSPI-5 2003 STANDARD FOR RESIDENTIAL INGROUND SWIMMING POOLS or ANSI/NSPI-1 1991 STANDARD FOR PUBLIC POOLS.
  - Measure the depth of water in front of the slide exit. (4-1/2' min. depth 4-1/2' from exit end of slide.)
  - Measure the height of the slide runway exit above the water. (20" max.)
  - Measure the distance between the slide centerline and the edge of other pool equipment.
6. Observe the position of the exit of the slide as shown in FIGURES J, K and L on pages 10 and 11.

## **IMPORTANT**

**PERSONALLY GIVE TO SLIDE OWNER THE SWIM CLUB II™ FUNSLIDE™ OWNER'S MANUAL, THE WARRANTY CARD AND ANSWER ALL QUESTIONS.**