

REVISIONS			
REV.	DESCRIPTION	DATE	ECN

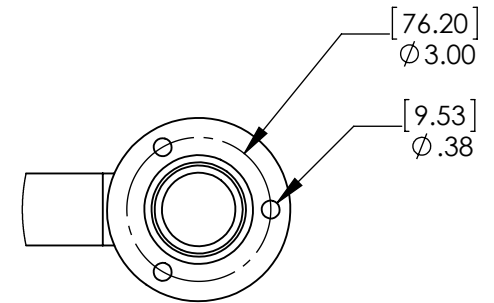
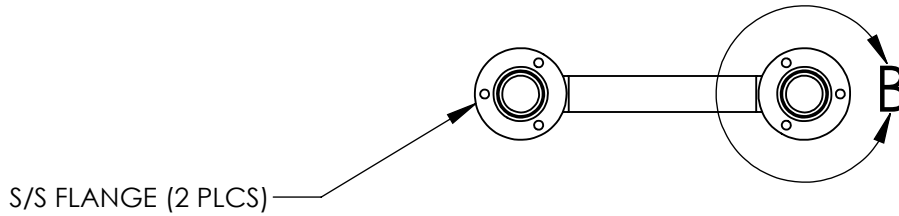
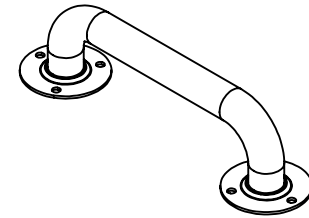
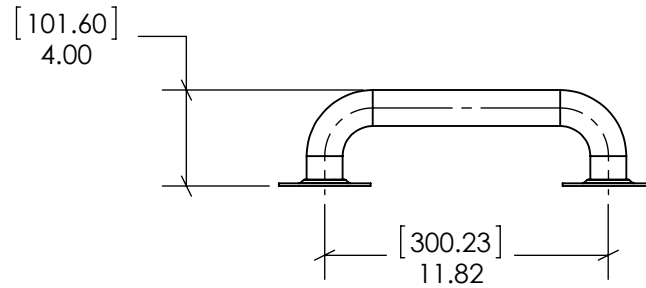

DETAIL B  
SCALE 1 : 4

TUBING LENGTH: 16.06"

UNLESS OTHERWISE SPECIFIED  
DIMENSIONS ARE IN INCHES,  
TOLERANCES ARE:  
FRACTIONAL: ..... ±1/16  
ANGULAR: ..... ±1°  
TWO PLACE DECIMAL: .... ±.06  
THREE PLACE DECIMAL: .. ±.031

DESCRIPTION:  
SAFETY RAIL - 300MM FLANGED

MATERIAL:  
1.50 x .049 (316L) S/S TUBING

PART NO.: SSR-300

REV. A

DRAWN BY: DTJ

DATE: 4/1/14

CHECKED BY:

DATE:



P.O. BOX 400 - 1017 S.W. BERG PARKWAY  
CANBY, OREGON 97013  
PHONE (503) 266-2231