

Double Anchor Socket Assembly

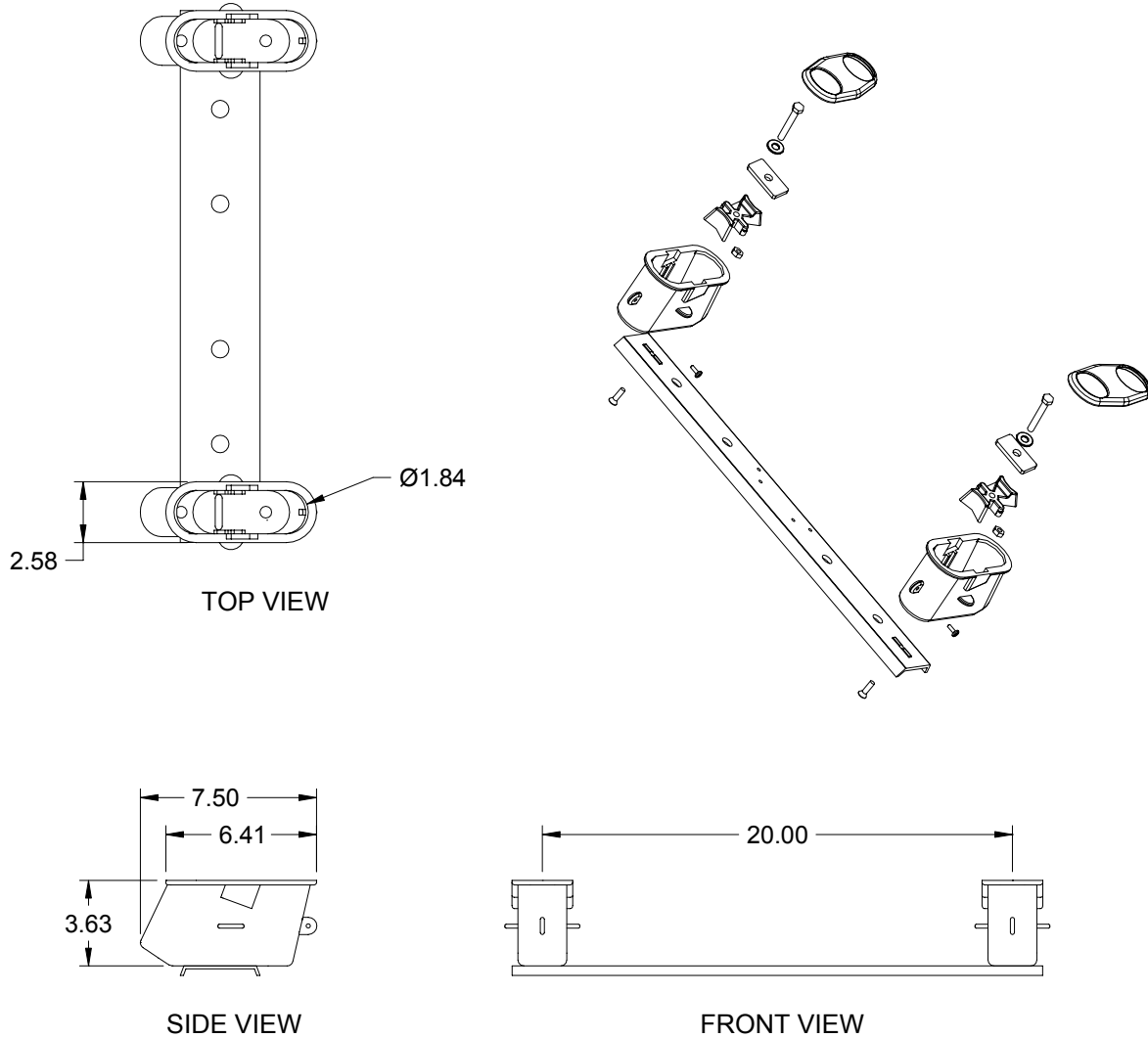

Specification: The Double Anchor Socket Assembly is designed to accept 1-5/8" (41.3mm) dia. ring rails. It is intended for heavy-duty commercial use and secures fixtures by means of a wedge assembly. A jig plate is used to install railings at 20" (508mm) on center. p/n 34-305A is made of cast aluminum, and p/n 34-306A is made of cast brass. Two chrome-plated bronze escutcheon plates are included.

Shipping Weight:

Model Number	Description	Shipping Weight
34-305A	Aluminum Anchor Assembly	10 lbs. (4.54kg)
34-306A	Bronze Anchor Assembly	13 lbs. (5.90kg)

Specification Number:	SRS-915		
Product Description:	Double Anchor Socket Assembly		
S.R. Smith Part Number:	34-305A, 34-306A	Scale:	NTS
Revision:	A	Date:	05/08/03
Written By:	T. Weil	Date:	05/08/03
Approved By:	B. Bisceglia	Date:	05/08/03
Page 1 of 1	Proprietary and confidential: The information contained in this specification is the sole property of S.R. Smith LLC. Any reproduction in part or whole without the written consent of S.R. Smith LLC is prohibited.		

S.R. Smith, LLC
P.O. Box 400, 1017 SW Berg Parkway
Canby, Oregon 97013
Tel: (888) 677-7776 (503) 266-2231
Fax: (503) 266-4334
www.srsmith.com